

E215 - SERIE

E219 - E220

CRANK HANDLE WITH THREADED INSERT AND REVOLVING HANDLE

Material: Reinforced polyamide. Oils and greases resistant.

Surface: Satin.

Colour: Black (RAL 9011).

Central Cap:

Grey polyamide RAL 7035 (cod. 13).

Alternative Cap Colour:

Orange (RAL 2004 cod. 02)

Red (RAL 3000 cod. 16)

Blue (RAL 5015 cod. 07)

Green (RAL 6024 cod. 17)

Yellow (RAL 1021 cod. 10)

Black (RAL 9011 cod. 01)

Main Insert:

Brass blind threaded bush.

(*) Zinc plated steel blind threaded bush.

Side Insert: Brass right through threaded bush.

Side Handle:

E215: Revolving handle Art. M144

E219: Revolving handle Art. M129

E220: Revolving handle Art. M145

SPECIAL REQUESTS:

- It is possible to supply the inserts in different materials, on request and for quantities.
- It is possible to supply arm and handle with colours as shown in the table at pag. 23, on request and for quantities.



Art. E215



Art. E219



Art. E220

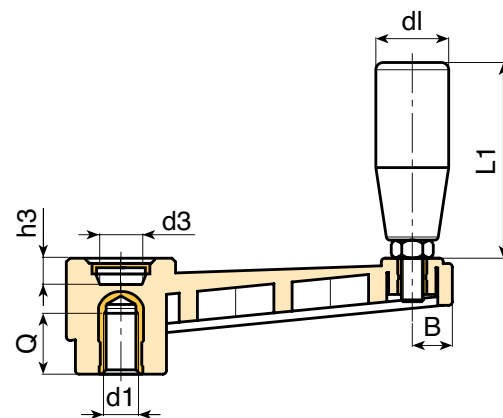
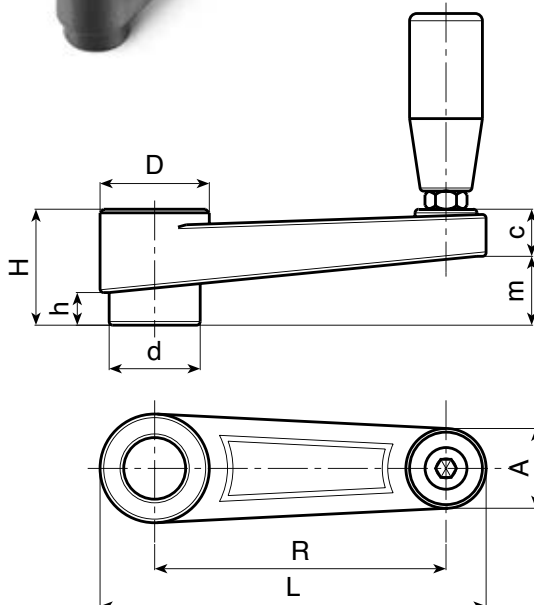

CRANK HANDLE WITH THREADED INSERT AND REVOLVING HANDLE

E215



PA6
+GF

UL94
HB



Art.	L	R	H	D	d	m	c	A	B	h	d3	h3	d1 6H	Q	dI	L1	△ g
● E215065.TM0801	88	65	30	27	22	17	13	18	9,5	8	14	10	M08	15	20	56	67
● E215065.TM1001	88	65	30	27	22	17	13	18	9,5	8	14	10	M10	15	20	56	70
● E215065.TM1201	88	65	30	27	22	17	13	18	9,5	8	14	10	M12	18	20	56	73
● E215080.TM0801	106	80	33	30	26	19	13	21,5	11	9	18	9	M08	18	20	56	83
● E215080.TM1001	106	80	33	30	26	19	13	21,5	11	9	18	9	M10	18	20	56	87
● E215080.TM1201	106	80	33	30	26	19	13	21,5	11	9	18	9	M12	18	20	56	90
● E215110.TM1001	138	110	39	33	29	25	14	22	12	11	18	11	M10	14	21	65	135
● E215110.TM1201	138	110	39	33	29	25	14	22	12	11	18	11	M12	18	21	65	137
● E215110.TM1401	138	110	39	33	29	25	14	22	12	11	18	11	M14	18	21	65	140
● E215140.TM1201	174	140	49	41	35	33	16	25,5	13,5	15	22	19	M12	19	23	76	238
● E215140.TM1401	174	140	49	41	35	33	16	25,5	13,5	15	22	19	M14	18	23	76	223
● E215140.TM1601	174	140	49	41	35	33	16	25,5	13,5	15	22	19	(*) M16	18	23	76	251
● E215185.TM1201	220	185	55	45	40	40	16,5	26,5	14	16,5	28	21	M12	17	25	86	312
● E215185.TM1401	220	185	55	45	40	40	16,5	26,5	14	16,5	28	21	M14	19	25	86	320
● E215185.TM1601	220	185	55	45	40	40	16,5	26,5	14	16,5	28	21	(*) M16	18	25	86	331

CRANK HANDLE WITH THREADED INSERT AND REVOLVING HANDLE M129

E219



PA6
+GF

UL94
HB



Art.	L	R	H	D	d	m	c	A	B	h	d3	h3	d1 6H	Q	dI	L1	△ g
● E219065.TM0801	88	65	30	27	22	17	13	18	9,5	8	14	10	M08	15	20	52	79
● E219065.TM1001	88	65	30	27	22	17	13	18	9,5	8	14	10	M10	15	20	52	82
● E219065.TM1201	88	65	30	27	22	17	13	18	9,5	8	14	10	M12	18	20	52	85
● E219080.TM0801	106	80	33	30	26	19	13	21,5	11	9	18	9	M08	18	20	52	95
● E219080.TM1001	106	80	33	30	26	19	13	21,5	11	9	18	9	M10	18	20	52	99
● E219080.TM1201	106	80	33	30	26	19	13	21,5	11	9	18	9	M12	18	20	52	102
● E219110.TM1001	138	110	39	33	29	25	14	22	12	11	18	11	M10	14	23	62	150
● E219110.TM1201	138	110	39	33	29	25	14	22	12	11	18	11	M12	18	23	62	160
● E219110.TM1401	138	110	39	33	29	25	14	22	12	11	18	11	M14	18	23	62	165
● E219140.TM1201	174	140	49	41	35	33	16	25,5	13,5	15	22	19	M12	19	25	72	262
● E219140.TM1401	174	140	49	41	35	33	16	25,5	13,5	15	22	19	M14	18	25	72	249
● E219140.TM1601	174	140	49	41	35	33	16	25,5	13,5	15	22	19	(*) M16	18	25	72	275
● E219185.TM1201	220	185	55	45	40	40	16,5	26,5	14	16,5	28	21	M12	17	25	82	312
● E219185.TM1401	220	185	55	45	40	40	16,5	26,5	14	16,5	28	21	M14	19	25	82	320
● E219185.TM1601	220	185	55	45	40	40	16,5	26,5	14	16,5	28	21	(*) M16	18	25	82	331

CRANK HANDLE WITH THREADED INSERT AND REVOLVING HANDLE M145

E220



PA6
+GF

UL94
HB



Art.	L	R	H	D	d	m	c	A	B	h	d3	h3	d1 6H	Q	dI	L1	△ g
● E220065.TM0801	88	65	30	27	22	17	13	18	9,5	8	14	10	M08	15	20	56	69
● E220065.TM1001	88	65	30	27	22	17	13	18	9,5	8	14	10	M10	15	20	56	72
● E220065.TM1201	88	65	30	27	22	17	13	18	9,5	8	14	10	M12	18	20	56	75
● E220080.TM0801	106	80	33	30	26	19	13	21,5	11	9	18	9	M08	18	20	56	85
● E220080.TM1001	106	80	33	30	26	19	13	21,5	11	9	18	9	M10	18	20	56	89
● E220080.TM1201	106	80	33	30	26	19	13	21,5	11	9	18	9	M12	18	20	56	92
● E220110.TM1001	138	110	39	33	29	25	14	22	12	11	18	11	M10	14	23	66	149
● E220110.TM1201	138	110	39	33	29	25	14	22	12	11	18	11	M12	18	23	66	151
● E220110.TM1401	138	110	39	33	29	25	14	22	12	11	18	11	M14	18	23	66	154
● E220140.TM1201	174	140	49	41	35	33	16	25,5	13,5	15	22	19	M12	19	25	77	228
● E220140.TM1401	174	140	49	41	35	33	16	25,5	13,5	15	22	19	M14	18	25	77	213
● E220140.TM1601	174	140	49	41	35	33	16	25,5	13,5	15	22	19	(*) M16	18	25	77	241
● E220185.TM1201	220	185	55	45	40	40	16,5	26,5	14	16,5	28	21	M12	17	25	87	304
● E220185.TM1401	220	185	55	45	40	40	16,5	26,5	14	16,5	28	21	M14	19	25	87	310
● E220185.TM1601	220	185	55	45	40	40	16,5	26,5	14	16,5	28	21	(*) M16	18	25	87	321

Presumable presence in the stock in %

() 90% (●) 40% (●) 5% (●) |

BOTECO® - © All right reserved - www.boteco.it

Any unauthorized reproduction is strictly forbidden



BOTECO

**E - FIXED AND INDEXED
CRANK HANDLES**