

Made in Germany

ATEK

ANTRIEBSTECHNIK

Das Winkelgetriebe



Bevel gearboxes
Type: V, VS, VL

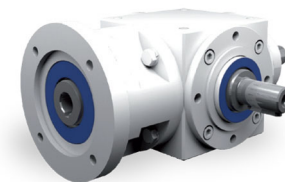
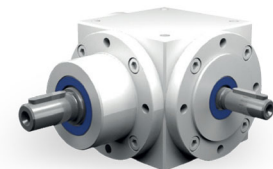

Miniature
bevel gearboxes

Bevel
gearboxes

Hygiene-design
gearboxes

Hybrid
gearboxes

Worm
gearboxes

Gearbox
motors

Servo gearboxes
(precision gearboxes)

Special
gearboxes

ATEX
gearboxes

Gear sets

Service



6.1 Type overview



Type V – Standard bevel gearboxes

Gear ratios: $i = 1:1$ to $6:1$
Maximum output torque: 5400 Nm
9 gearbox sizes with edge lengths of 065 to 350 mm
Low-backlash construction < 6 angular minutes possible
Housing made of grey cast iron or steel

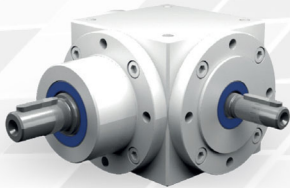

Type VS – Type V with step-up ratio

Gear ratios: $i = 1:1.5$ and $1:2$
Maximum output torque: 1200 Nm
6 gearbox sizes with edge lengths of 090 to 260 mm
Low-backlash construction < 10 angular minutes possible
Larger shaft diameter (N_2), slowly rotating
Housing made of grey cast iron or steel

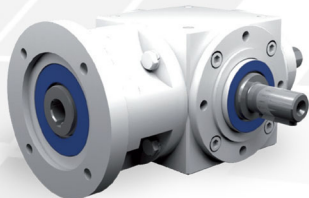

Type VL – Type V with flange

Gear ratios: $i = 1:1$ to $6:1$
Maximum output torque: 2310 Nm
8 gearbox sizes with edge lengths of 065 to 260 mm
Low-backlash construction < 6 angular minutes possible
Suitable for fitting IEC standard motors
Drive side with hollow-bored shaft and flange
Housing made of grey cast iron or steel

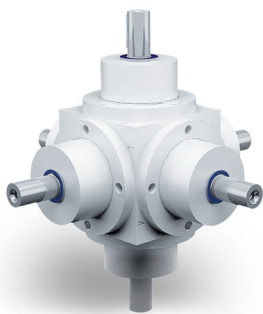

Multi shaft gearbox – with additional shafts

for gear ratios of $1.5:1$ to $6:1$ with type V
for gear ratios of $1.5:1$ to $2:1$ with type VS
with solid shaft or hollow shaft
up to 6 shaft ends

6.2 General construction

A bevel gearbox enables alternatively stepping-down or stepping-up.

The axles intersect in the gearbox in an angle of 90°. The edge length of the housing is reflected in the gearbox size (example: V 120 – housing edge length 120 mm).

6.2.1 Toothing

ATEK bevel gearboxes have gear sets with high-quality spiral toothing made of hardened carburised steel. A gear set comprises one bevel pinion (small number of teeth / small diameter) and one bevel gear (large number of teeth / large diameter). Gear sets with spiral toothing offer the advantage of very favourable engagement factors (high meshing ratio). Therefore they are predestined for usage with high loads, combined with optimal running smoothness and high transmission accuracy.

6.2.2 Construction types

Due to the modular system, different gearbox construction types can be configured. The construction types vary in

| Construction type | No. of gear sets | Additional gears |
|--------------------|------------------|--------------------------------|
| A0 through E0 | 1 gear set | |
| F0 through K0 | 1 gear set | + 1 bevel pinion or bevel gear |
| Branch-off gearbox | 1 gear set | + 2–3 bevel pinions/gears |

Table 6.2.2-1

The construction types differ in type and number of the shafts, the rotational direction of the shafts and their support by bearings.

Example of order code: V 090 1:1 A0 - 1.1 -1000 /0000

6.2.3 Threaded mounting holes

All 6 sides of the gearboxes are machined and may be used as mounting surfaces. All flanges always have threaded mounting holes. You have the following available ordering options:

| Ordering options | Threaded mounting holes are in the housing surfaces on the gearbox side | Threaded mounting holes are in the flanges on the gearbox side |
|------------------|---|--|
| 0 | - | 3, 5, 6 |
| 1, 2, 3, 4, 5, 6 | 1, 2, 4 | 3, 5, 6 |
| 9 | 1, 2, 4 | 3, 5, 6 |

Table 6.2.3-1

The standard version has the order code 9.

Example of order code for mounting option 9: V 090 1:1 A0 - 9.1 -1000 /0000

Other mounting options must be enquired.

6.2.4 Installation position

The installation position is defined by the gearbox side directed downwards during operation and will be indicated by the associated numeral. The gearboxes can be used in all installation positions. The technically most favourable and thus recommended installation position is the position in which the shafts are horizontal. These are the installation positions 1 and 2.

Please contact us for consultation if the angle of the gearbox side directed downwards deviates more than 15° from the horizontal position.

For an optimal technical design of the gearboxes, we principally ask to specify the installation position.

Example of order code for installation position 2: V 090 1:1 A0 - 1.2 -1000 /0000

6.2.5 Shaft designation – allocation to the gearbox sides

The fast-rotating shaft has the speed n_1 and is identified by N_1 .

The bevel pinion is located on this shaft. The slowly rotating shaft has the speed n_2 and is identified by N_2 .

The bevel gear is located on this shaft.

The gearbox sides are identified by the numerals 1 to 6 (see Figure 4.3.1-1; Gearbox sides)

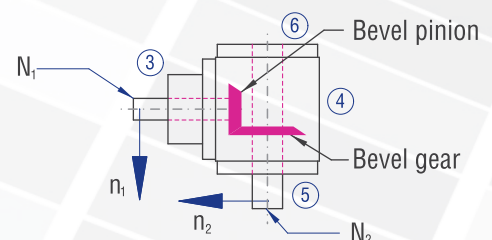

Figure 6.2.5-1; Shaft designations

6.2.6 Preferred direction of rotation

If the clockwise (CW) direction of rotation (viewing direction from shaft end face of the fast-rotating shaft towards the gearbox centre) is selected, a 1 to 2 dB(A) lower noise level is generated.

6 Bevel gearboxes

6.2.7 Efficiency

The achievable efficiency depends on rotational speed, torque, installation position, sealing, and lubricant type.

With gearboxes having only one gear set, an efficiency of 97% can be achieved. With gearboxes having several gear meshings, an efficiency of 94% can be achieved. The efficiencies specified in the tables relate to the permissible nominal load and are guidance values for run-in gearboxes at operating temperature with standard sealing.

6.2.8 Lubrication

With the bevel gearboxes, different conditions for the lubrication will arise depending on gearbox size, rotational speed, on-period, temperature, and type of application. The decisive variable is the circumferential speed of the bevel gear. Depending thereon, different oil quantities and viscosities will be used.

These will be defined by ATEK based on your ordering details (rotational speed, on-period, and ambient temperature).

They will be reflected in the type designation. You can find the itemisation in the example: V 090 1:1 C0 - 1.1 -1000 /B0

Here, /B0 means:

| | Abbreviation | Explanation | Reference |
|---------|--------------|-------------------|---------------|
| Letter | B | Oil viscosity 220 | Table 6.2.8-1 |
| Numeral | 0 | no venting | Table 6.2.8-2 |

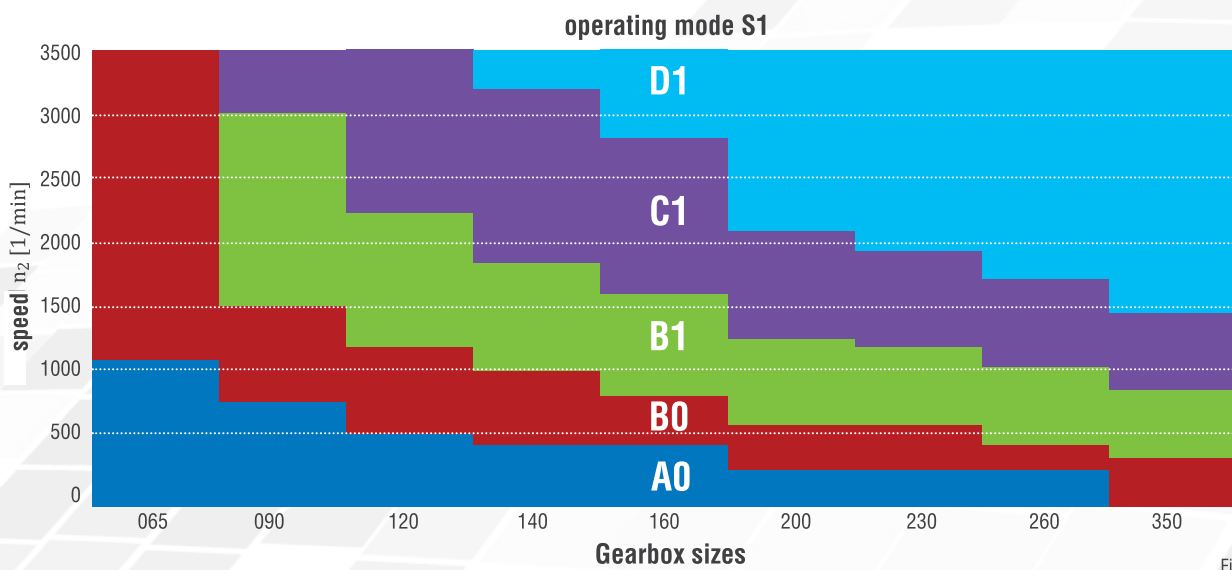

Figure 6.2.8-1

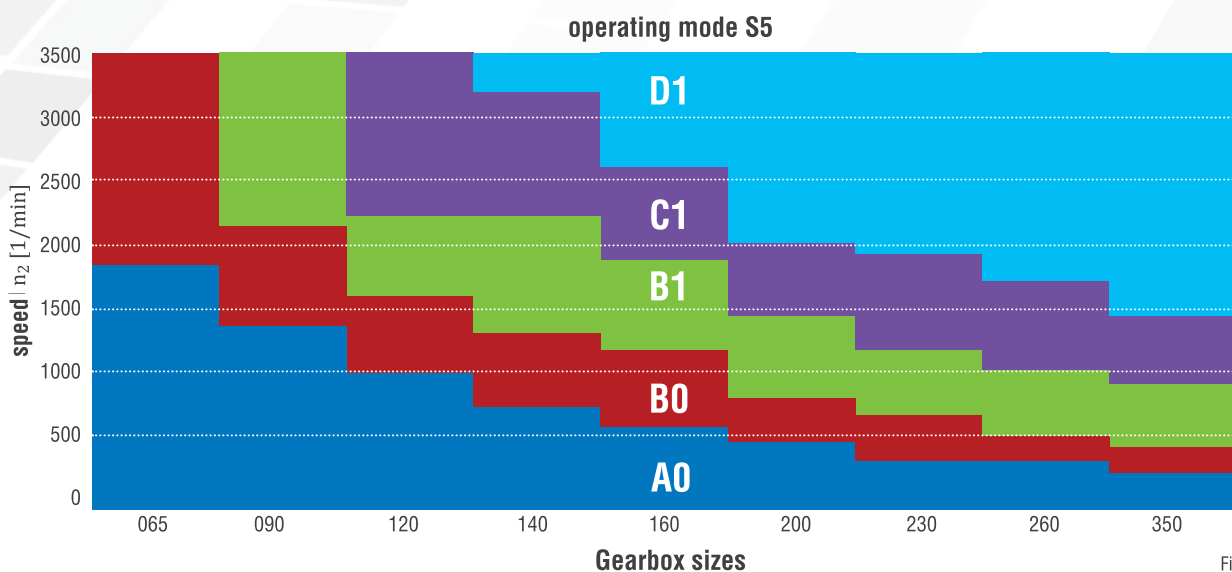

Figure 6.2.8-2

For the abbreviations, refer to the following tables.

Oil viscosity table

| Letter | Viscosity |
|--------|-----------------------|
| A | 460 |
| B | 220 |
| C | 68 |
| D | Injection lubrication |
| F | Fluid grease |

Table 6.2.8-1

Depending on the gearbox size, injection lubrication may be necessary in case of high rotational speeds. In case of very low rotational speeds, lubrication by fluid grease is also possible.

| Numeral | Vent filter |
|---------|-------------|
| 0 | No |
| 1 | Yes |

Table 6.2.8-2

6.2.9 Vent filter

If venting is required (B1 or C1) the gearboxes will be delivered with a vent filter. The vent bores will be equipped with screw plugs for transport. The vent filter will be enclosed as a separate item and must be mounted in the intended position prior to commissioning. An elbow may be required. Please adhere to the operating instructions!

| Gearbox size | V065 | V090 | V120 | V140 | V160 | V200 | V230 | V350 |
|--------------|------|------|------|------|------|------|------|------|
| Pipe thread | G1/4 | G1/4 | G3/8 | G3/8 | G1/2 | G1/2 | G1/2 | G1/2 |

The position of the filter will be specified in the order documents. Please refer to the following table for the position of the filter. The meaning here, for example: /B1-E4 = oil viscosity 220; vent filter on side 4.

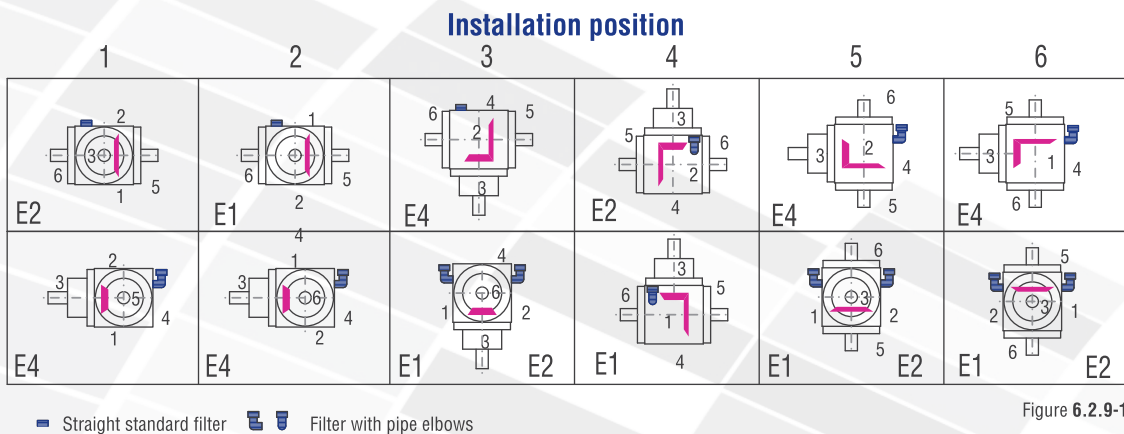

Figure 6.2.9-1

6.2.10 Low-backlash construction

For optimal running, the tooth space in the gear set is manufactured larger than the tooth. When the direction of rotation is changed, this results in a rotation angle until the counter-rotating tooth flanks contact each other. This rotation angle is called circumferential backlash.

Circumferential backlash, measuring method

The circumferential backlash is measured after the shaft N_1 has been fixed. A force of around 2% of the nominal torque is applied to the shaft N_2 in both rotational directions. A tooth backlash will result between the two final positions. This can be measured as rotation angle and is indicated in minutes of arc [arcmin].

Circumferential backlash, type

All ATEK bevel gearboxes can be delivered as low-backlash types. (u.r. – upon request)

| Ordering option | Gear set | 1:1, 2:1 | 3:1, 4:1, 5:1, 6:1 |
|-----------------|------------------|------------------|--------------------|
| /0000 | Standard | ≤ 30 arcmin | ≤ 30 arcmin |
| /S2 | Standard | ≤ 10 arcmin | ≤ 10 arcmin |
| /S1 | Standard | ≤ 6 arcmin | u.r. |
| /S0 | Special gear set | ≤ 4 arcmin | u.r. |

Abbreviation: u.r. – upon request

Table 6.2.10-1

6.3 Type V – Standard bevel gearboxes

6.3.1 Features

Gear ratios: $i = 1:1$ to $6:1$

Maximum output torque: 5400 Nm

9 gearbox sizes with edge lengths of 065 to 350 mm

Low-backlash construction < 6 angular minutes possible

Housing made of grey cast iron or steel

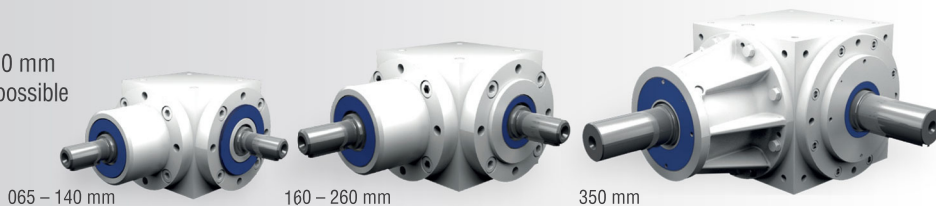

6.3.2 Models

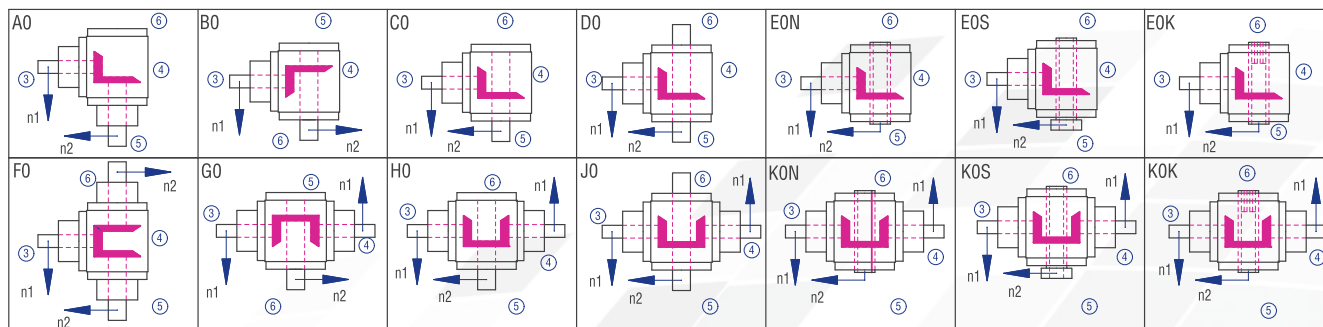

Figure 6.3.2-1; Models

6.3.3 Gearbox sides

The example shows the Model C0

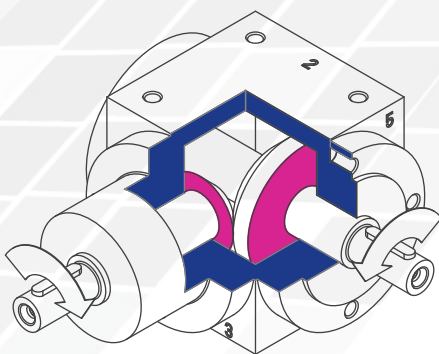

Figure 6.3.3-1; Gearbox sides

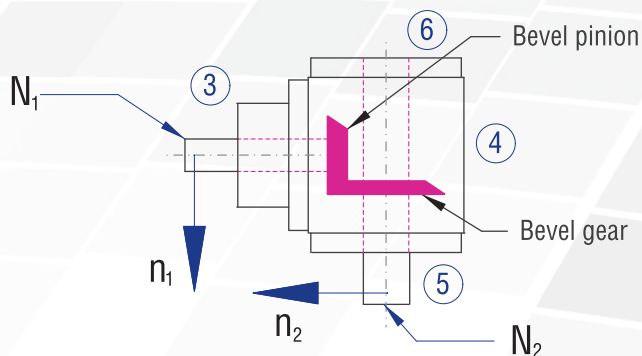

Figure 6.3.3-2; Shaft designations

6.3.4 Order code

The order code reflects the customer specifications. Example:

| Type | Size | Gear ratio | Model | Fixing side | Installation position | Speed n_2 | Design |
|--------------------|------------------------------------|---------------|------------------------|--|--|--------------------------------------|----------|
| V | 065 | 1:1 | C0- | 1. | 1- | 1500 | /0000 |
| Description | Housing edge length; Table 6.3.5-1 | Table 6.3.5-1 | Figure 6.3.2-1; Models | Gearbox side on which fixing is made; Table 6.2.3-1; Figure 4.3.1-1; Gearbox sides | Gearbox side directed downwards; Figure 4.3.1-1; Gearbox sides | Slowly rotating shaft; Table 6.3.5-1 | Standard |

Table 6.3.4-1

6.3.6 Type V 065 – Standard bevel gearboxes

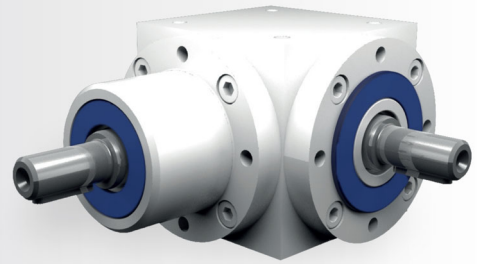

Characteristics

| Characteristic | Standard | Option |
|---------------------------------|--|--------------------|
| Toothing | Spiral toothed bevel gear set | See chapter 6.2.1 |
| Gear ratio | 1:1 to 3:1 | |
| Housing / Flanges | Grey cast iron; steel | |
| Threaded mounting hole | On all housing surfaces without flange and on all flanges. | See chapter 6.2.3 |
| Shaft | Material 1 C45, shaft ends greased Fit with ISO 6 tolerance with parallel keyway: according to DIN 6885 Sheet 1 | See chapter 4.6.2 |
| Hollow shaft | Material 1 C45, shafts greased Fit with ISO 7 tolerance with parallel keyway: according to DIN 6885 Sheet 1 | See chapter 4.6.3 |
| Radial shaft seal ring | NBR, form A | See chapter 4.8 |
| Ambient temperature | -10°C to +90°C. The values of the performance tables are valid for +20°C | See chapter 4.9.3 |
| Circumferential backlash | < 30 arcmin | See chapter 6.2.10 |
| Protection class | IP 54 | See chapter 4.5 |
| Corrosion protection | Prime coat; layer thickness > 40 µm | See chapter 4.4.1 |
| Bearing life L10h | more than 15,000h | See chapter 4.9.1 |
| Oil change intervals | Not required if the oil temperature is kept < 90°C The lifetime of the bearings can be increased by the factor 1.5 if the oil is changed after the first 500 service hours and then every 5000 service hours. | See chapter 6.2.8 |
| Lubricant | Synthetic lubricants | See chapter 6.2.8 |

Performance data

| n_1 [rpm] | 1:1 | | | 1.5:1 | | | 2:1 | | | 3:1 | | | 4:1 | | | 5:1 | | | 6:1 | | | |
|-----------------|----------------|------------------|------------------|----------------|------------------|------------------|----------------|------------------|------------------|----------------|------------------|------------------|----------------|------------------|------------------|----------------|------------------|------------------|----------------|------------------|------------------|--|
| | n_2 [rpm] | P_{1N} [kW] | T_{2N} [Nm] | n_2 [rpm] | P_{1N} [kW] | T_{2N} [Nm] | n_2 [rpm] | P_{1N} [kW] | T_{2N} [Nm] | n_2 [rpm] | P_{1N} [kW] | T_{2N} [Nm] | n_2 [rpm] | P_{1N} [kW] | T_{2N} [Nm] | n_2 [rpm] | P_{1N} [kW] | T_{2N} [Nm] | n_2 [rpm] | P_{1N} [kW] | T_{2N} [Nm] | |
| 3000 | 3000 | 3.31 | 10 | 2000 | 2.20 | 10 | 1500 | 1.65 | 10 | 1000 | 1.10 | 10 | | | | | | | | | | |
| 2400 | 2400 | 2.65 | 10 | 1600 | 1.76 | 10 | 1200 | 1.32 | 10 | 800 | 0.88 | 10 | | | | | | | | | | |
| 1500 | 1500 | 1.82 | 11 | 1000 | 1.21 | 11 | 750 | 0.91 | 11 | 500 | 0.61 | 11 | | | | | | | | | | |
| 1000 | 1000 | 1.32 | 12 | 667 | 0.88 | 12 | 500 | 0.66 | 12 | 333 | 0.44 | 12 | | | | | | | | | | |
| 750 | 750 | 1.07 | 13 | 500 | 0.72 | 13 | 375 | 0.54 | 13 | 250 | 0.33 | 12 | | | | | | | | | | |
| 500 | 500 | 0.83 | 15 | 333 | 0.55 | 15 | 250 | 0.41 | 15 | 167 | 0.24 | 13 | | | | | | | | | | |
| 250 | 250 | 0.47 | 17 | 167 | 0.31 | 17 | 125 | 0.23 | 17 | 83 | 0.12 | 13 | | | | | | | | | | |
| 50 | 50 | 0.10 | 18 | 33 | 0.07 | 18 | 25 | 0.05 | 18 | 17 | 0.03 | 14 | | | | | | | | | | |
| P_{1Nt} [kW] | 1.6 | | | 1.6 | | | 1.6 | | | 1.6 | | | | | | | | | | | | |
| T_{2max} [Nm] | 25 | | | 25 | | | 25 | | | 23 | | | | | | | | | | | | |

Permissible radial force F_{r1} and axial force F_{a1} on shaft N_1

| n_1 [rpm] | 3000 | | 1000 | | 500 | | 250 | | 100 | | 50 | |
|-------------|-----------|-----------|-----------|-----------|-----------|-----------|-----------|-----------|-----------|-----------|-----------|-----------|
| T_2 [Nm] | F_r [N] | F_a [N] | F_r [N] | F_a [N] | F_r [N] | F_a [N] | F_r [N] | F_a [N] | F_r [N] | F_a [N] | F_r [N] | F_a [N] |
| < 12 | 180 | 90 | 250 | 125 | 300 | 150 | 350 | 175 | 450 | 225 | 550 | 275 |
| > 12 | 150 | 75 | 210 | 105 | 250 | 125 | 290 | 145 | 380 | 190 | 460 | 230 |

Permissible radial force F_{r2} and axial force F_{a2} on shaft N_2

| n_2 [rpm] | 3000 | | 1000 | | 500 | | 250 | | 100 | | 50 | |
|-------------|-----------|-----------|-----------|-----------|-----------|-----------|-----------|-----------|-----------|-----------|-----------|-----------|
| T_2 [Nm] | F_r [N] | F_a [N] | F_r [N] | F_a [N] | F_r [N] | F_a [N] | F_r [N] | F_a [N] | F_r [N] | F_a [N] | F_r [N] | F_a [N] |
| < 12 | 300 | 150 | 400 | 200 | 500 | 250 | 650 | 325 | 750 | 375 | 900 | 450 |
| > 12 | 250 | 125 | 330 | 165 | 420 | 210 | 540 | 270 | 630 | 315 | 750 | 375 |

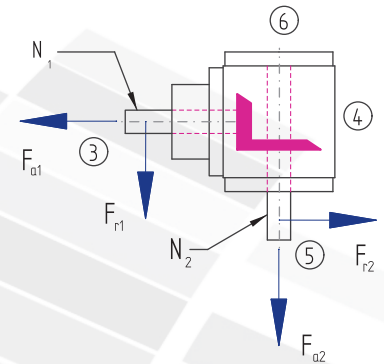

Inertia moments/mass

Inertia moment J_1 related to the fast-rotating shaft (N_1)

| Model | Inertia moment [kgcm ²] | | | | | | | Mass [kg] |
|-------|-------------------------------------|---------|---------|---------|-----|-----|-----|-----------|
| | 1:1 | 1.5:1 | 2:1 | 3:1 | 4:1 | 5:1 | 6:1 | |
| A0 | 0.38880 | 0.24060 | 0.18390 | 0.10360 | | | | 2.3 |
| B0 | 0.42310 | 0.31110 | 0.23300 | 0.10010 | | | | 2.2 |
| C0 | 0.42310 | 0.31110 | 0.23300 | 0.10010 | | | | 2.2 |
| D0 | 0.43300 | 0.31550 | 0.23550 | 0.10120 | | | | 2.3 |
| E0N | 0.47540 | 0.36340 | 0.28530 | 0.15240 | | | | 2.1 |
| E0S | 0.60120 | 0.48920 | 0.41110 | 0.27820 | | | | 2.1 |
| F0 | 0.58320 | 0.32700 | 0.23250 | 0.12520 | | | | 2.7 |
| G0 | 0.61750 | 0.46530 | 0.36830 | 0.18210 | | | | 2.6 |
| H0 | 0.61750 | 0.46530 | 0.36830 | 0.18210 | | | | 2.6 |
| J0 | 0.62740 | 0.46970 | 0.37080 | 0.18320 | | | | 2.7 |
| K0N | 0.66980 | 0.51760 | 0.42060 | 0.23440 | | | | 2.5 |
| K0S | 0.79560 | 0.64340 | 0.54640 | 0.36020 | | | | 2.5 |

6.3.6 Type V 065 – Standard bevel gearboxes

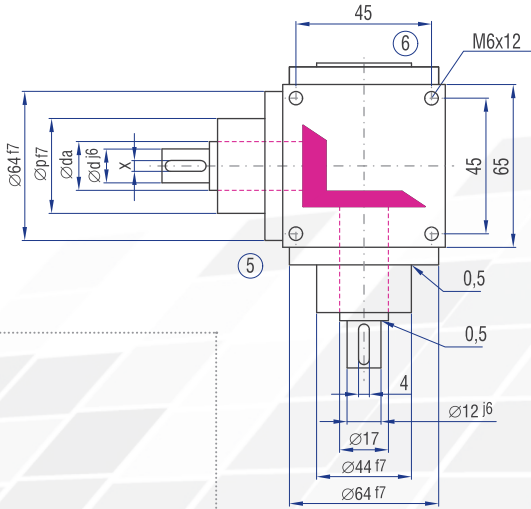
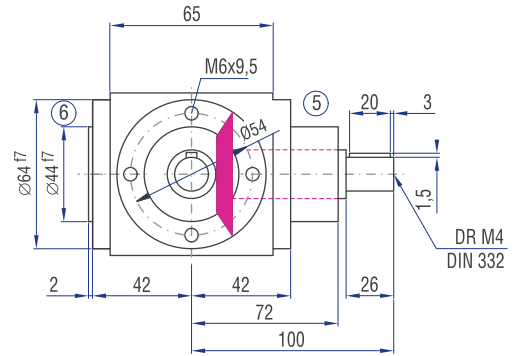
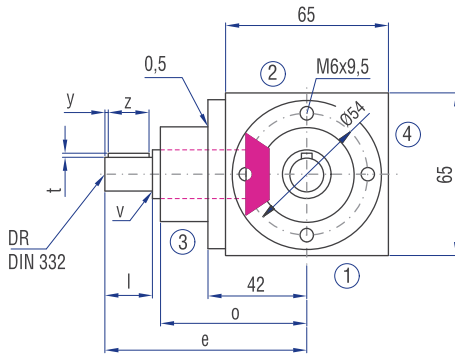
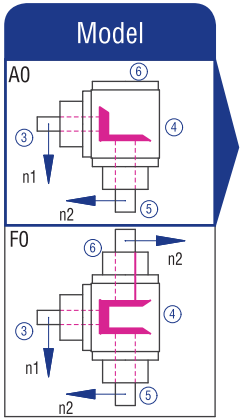

| | Gear ratio | | | | | | |
|---------|------------|-------|-----|-----|-----|-----|-----|
| | 1:1 | 1.5:1 | 2:1 | 3:1 | 4:1 | 5:1 | 6:1 |
| d [mm] | 12 | 12 | 12 | 12 | | | |
| da [mm] | 17 | 17 | 17 | 17 | | | |
| l [mm] | 26 | 26 | 26 | 26 | | | |
| v [mm] | 0.5 | 0.5 | 0.5 | 0.5 | | | |
| x [mm] | 4 | 4 | 4 | 4 | | | |
| y [mm] | 3 | 3 | 3 | 3 | | | |
| z [mm] | 20 | 20 | 20 | 20 | | | |
| t [mm] | 1.5 | 1.5 | 1.5 | 1.5 | | | |
| e [mm] | 100 | 100 | 100 | 100 | | | |
| o [mm] | 72 | 72 | 72 | 72 | | | |
| p [mm] | 44 | 44 | 44 | 44 | | | |
| DR M | 4 | 4 | 4 | 4 | | | |

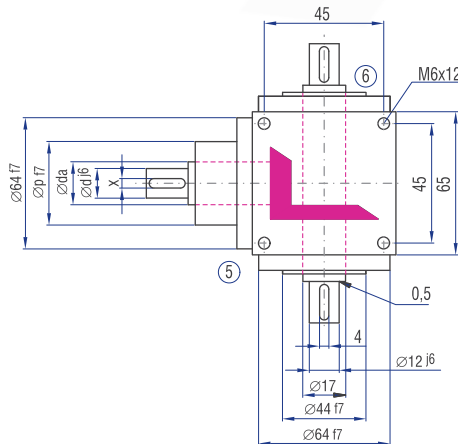
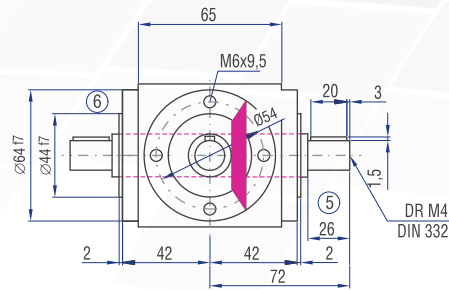
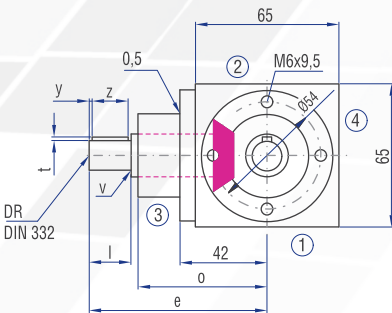
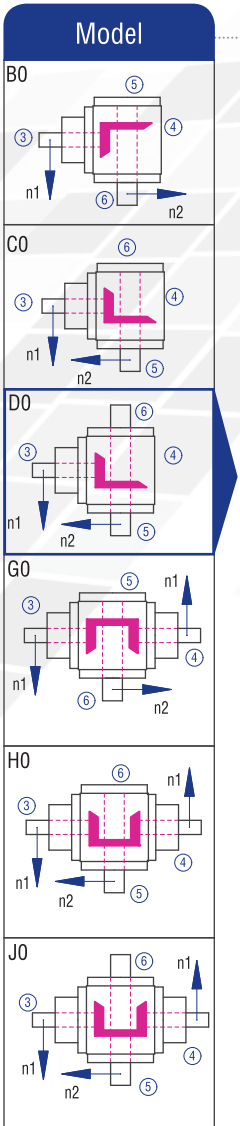

Implementation vv

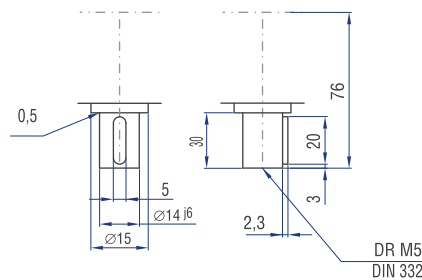

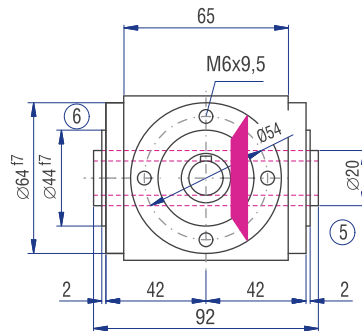
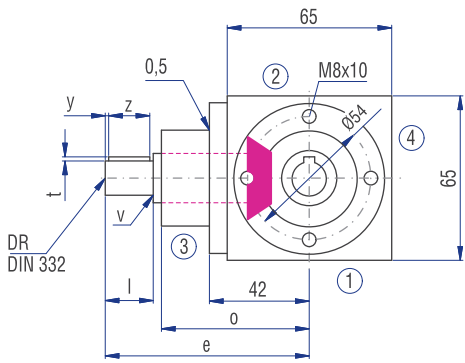

Implementation

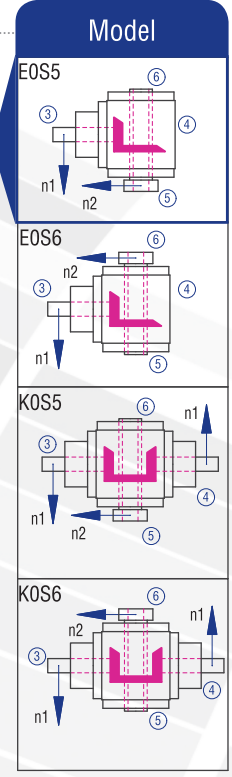
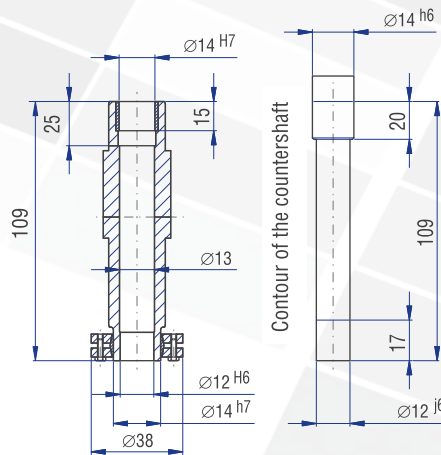
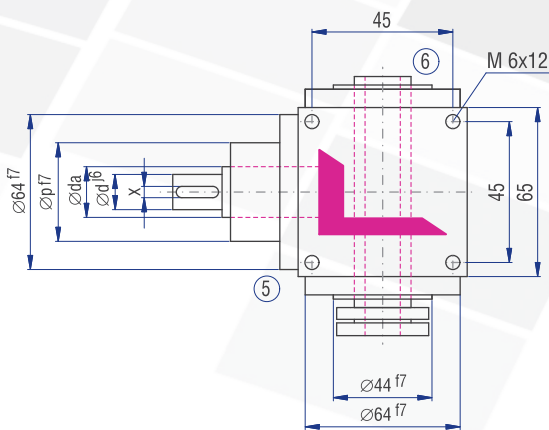
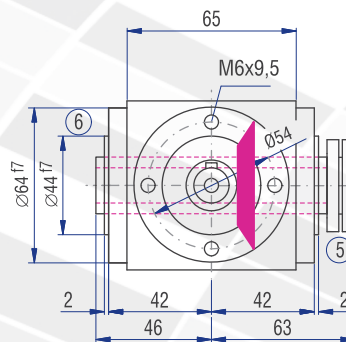
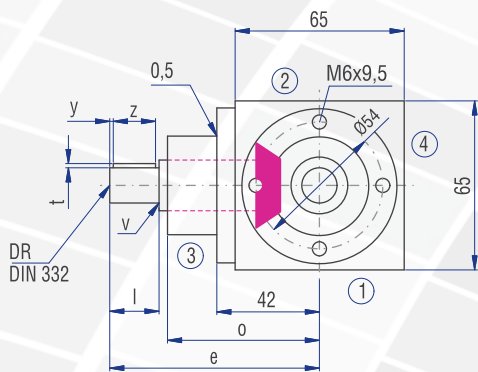
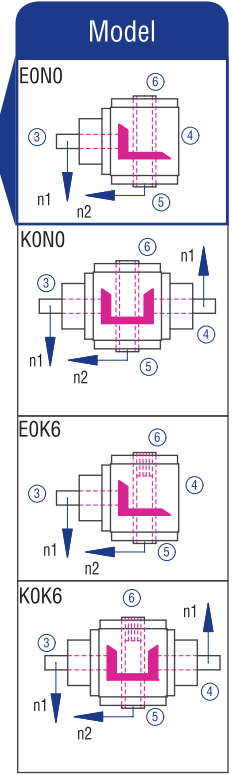
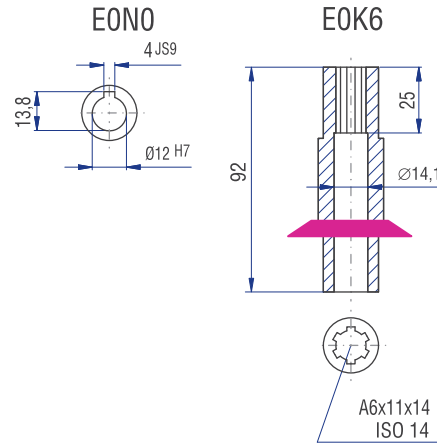
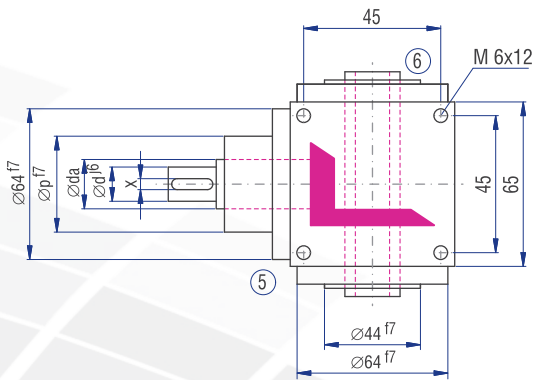

6.3.7 Type V 090 – Standard bevel gearboxes

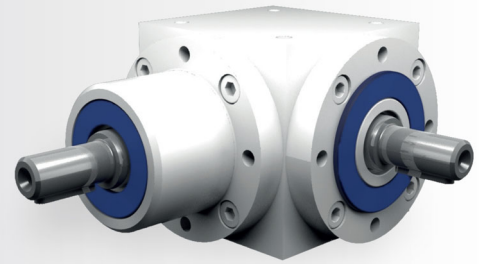

Characteristics

| Characteristic | Standard | Option |
|---------------------------------|--|--------------------|
| Toothing | Spiral toothed bevel gear set | See chapter 6.2.1 |
| Gear ratio | 1:1 to 6:1 | |
| Housing / Flanges | Grey cast iron; steel | |
| Threaded mounting hole | On all housing surfaces without flange and on all flanges. | See chapter 6.2.3 |
| Shaft | Material 1 C45, shaft ends greased Fit with ISO 6 tolerance with parallel keyway: according to DIN 6885 Sheet 1 | See chapter 4.6.2 |
| Hollow shaft | Material 1 C45, shafts greased Fit with ISO 7 tolerance with parallel keyway: according to DIN 6885 Sheet 1 | See chapter 4.6.3 |
| Radial shaft seal ring | NBR, form A | See chapter 4.8 |
| Ambient temperature | -10°C to +90°C. The values of the performance tables are valid for +20°C | See chapter 4.9.3 |
| Circumferential backlash | < 30 arcmin | See chapter 6.2.10 |
| Protection class | IP 54 | See chapter 4.5 |
| Corrosion protection | Prime coat; layer thickness > 40 µm | See chapter 4.4.1 |
| Bearing life L10h | more than 15,000h | See chapter 4.9.1 |
| Oil change intervals | Not required if the oil temperature is kept < 90°C The lifetime of the bearings can be increased by the factor 1.5 if the oil is changed after the first 500 service hours and then every 5000 service hours. | See chapter 6.2.8 |
| Lubricant | Synthetic lubricants | See chapter 6.2.8 |

Performance data

| n_1 [rpm] | 1:1 | | | 1.5:1 | | | 2:1 | | | 3:1 | | | 4:1 | | | 5:1 | | | 6:1 | | |
|----------------|----------------|------------------|------------------|----------------|------------------|------------------|----------------|------------------|------------------|----------------|------------------|------------------|----------------|------------------|------------------|----------------|------------------|------------------|----------------|------------------|------------------|
| | n_2 [rpm] | P_{1N} [kW] | T_{2N} [Nm] | n_2 [rpm] | P_{1N} [kW] | T_{2N} [Nm] | n_2 [rpm] | P_{1N} [kW] | T_{2N} [Nm] | n_2 [rpm] | P_{1N} [kW] | T_{2N} [Nm] | n_2 [rpm] | P_{1N} [kW] | T_{2N} [Nm] | n_2 [rpm] | P_{1N} [kW] | T_{2N} [Nm] | n_2 [rpm] | P_{1N} [kW] | T_{2N} [Nm] |
| 3000 | 3000 | 8.93 | 27 | 2000 | 5.51 | 25 | 1500 | 3.80 | 23 | 1000 | 2.54 | 23 | 750 | 1.90 | 23 | 600 | 1.52 | 23 | 500 | 1.25 | 23 |
| 2400 | 2400 | 7.41 | 28 | 1600 | 4.59 | 26 | 1200 | 3.17 | 24 | 800 | 2.12 | 24 | 600 | 1.65 | 25 | 480 | 1.32 | 25 | 400 | 1.09 | 25 |
| 1500 | 1500 | 5.29 | 32 | 1000 | 3.20 | 29 | 750 | 2.23 | 27 | 500 | 1.49 | 27 | 375 | 1.12 | 27 | 300 | 0.89 | 27 | 250 | 0.74 | 27 |
| 1000 | 1000 | 3.75 | 34 | 667 | 2.35 | 32 | 500 | 1.71 | 31 | 333 | 1.14 | 31 | 250 | 0.85 | 31 | 200 | 0.68 | 31 | 167 | 0.53 | 29 |
| 750 | 750 | 3.06 | 37 | 500 | 1.93 | 35 | 375 | 1.32 | 32 | 250 | 0.88 | 32 | 188 | 0.66 | 32 | 150 | 0.53 | 32 | 125 | 0.40 | 29 |
| 500 | 500 | 2.20 | 40 | 333 | 1.36 | 37 | 250 | 0.94 | 34 | 167 | 0.63 | 34 | 125 | 0.47 | 34 | 100 | 0.37 | 34 | 83 | 0.27 | 29 |
| 250 | 250 | 1.21 | 44 | 167 | 0.74 | 40 | 125 | 0.50 | 36 | 83 | 0.33 | 36 | 63 | 0.25 | 36 | 50 | 0.20 | 36 | 42 | 0.14 | 30 |
| 50 | 50 | 0.28 | 50 | 33 | 0.16 | 45 | 25 | 0.10 | 37 | 17 | 0.07 | 37 | 13 | 0.05 | 37 | 10 | 0.04 | 37 | 8 | 0.03 | 33 |

| | | | | | | |
|-----------------|-----|-----|-----|-----|-----|-----|
| P_{1Nt} [kW] | 3.8 | 3.8 | 3.8 | 3.8 | 3.8 | 3.8 |
| T_{2max} [Nm] | 105 | 80 | 80 | 70 | 70 | 50 |

Permissible radial force F_{r1} and axial force F_{a1} on shaft N_1

| n_1 [rpm] | 3000 | | 1000 | | 500 | | 250 | | 100 | | 50 | |
|-------------|-----------|-----------|-----------|-----------|-----------|-----------|-----------|-----------|-----------|-----------|-----------|-----------|
| T_2 [Nm] | F_r [N] | F_a [N] | F_r [N] | F_a [N] | F_r [N] | F_a [N] | F_r [N] | F_a [N] | F_r [N] | F_a [N] | F_r [N] | F_a [N] |
| < 30 | 300 | 150 | 400 | 200 | 470 | 235 | 580 | 290 | 700 | 350 | 800 | 400 |
| > 30 | 250 | 125 | 330 | 165 | 390 | 195 | 490 | 245 | 590 | 295 | 670 | 335 |

Permissible radial force F_{r2} and axial force F_{a2} on shaft N_2

| n_2 [rpm] | 3000 | | 1000 | | 500 | | 250 | | 100 | | 50 | |
|-------------|-----------|-----------|-----------|-----------|-----------|-----------|-----------|-----------|-----------|-----------|-----------|-----------|
| T_2 [Nm] | F_r [N] | F_a [N] | F_r [N] | F_a [N] | F_r [N] | F_a [N] | F_r [N] | F_a [N] | F_r [N] | F_a [N] | F_r [N] | F_a [N] |
| < 30 | 500 | 250 | 660 | 330 | 800 | 400 | 950 | 475 | 1250 | 625 | 1500 | 750 |
| > 30 | 420 | 210 | 550 | 275 | 670 | 335 | 790 | 395 | 1040 | 520 | 1250 | 625 |

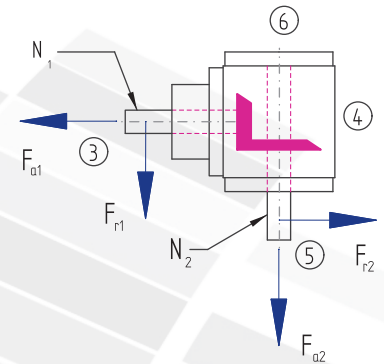

Inertia moments/mass

Inertia moment J_1 related to the fast-rotating shaft (N_1)

| Model | Inertia moment [kgcm ²] | | | | | | | Mass [kg] |
|-------|-------------------------------------|---------|---------|---------|---------|---------|---------|-----------|
| | 1:1 | 1.5:1 | 2:1 | 3:1 | 4:1 | 5:1 | 6:1 | |
| A0 | 2.55900 | 1.48220 | 1.14370 | 0.88840 | 0.36310 | 0.32480 | 0.30620 | 5.1 |
| B0 | 3.35430 | 2.18330 | 1.36520 | 1.04650 | 0.46070 | 0.39330 | 0.35020 | 5.4 |
| C0 | 3.35430 | 2.18330 | 1.36520 | 1.04650 | 0.46070 | 0.39330 | 0.35020 | 5.4 |
| D0 | 3.38270 | 2.19590 | 1.37230 | 1.04960 | 0.46250 | 0.39450 | 0.35100 | 5.5 |
| E0N | 3.25070 | 2.13720 | 1.33930 | 1.03500 | 0.45420 | 0.38920 | 0.34730 | 5.0 |
| E0S | 3.92130 | 2.43530 | 1.50690 | 1.10950 | 0.49610 | 0.41600 | 0.36600 | 5.2 |
| F0 | 3.83850 | 2.05080 | 1.46360 | 1.03050 | 0.44300 | 0.37600 | 0.34180 | 6.3 |
| G0 | 4.63380 | 3.09680 | 2.18900 | 1.79270 | 0.74380 | 0.66690 | 0.62090 | 6.9 |
| H0 | 4.63380 | 3.09680 | 2.18900 | 1.79270 | 0.74380 | 0.66690 | 0.62090 | 6.9 |
| J0 | 4.66220 | 3.10940 | 2.19610 | 1.79580 | 0.74560 | 0.66810 | 0.62170 | 7.0 |
| K0N | 4.53020 | 3.05070 | 2.16310 | 1.78120 | 0.73730 | 0.66280 | 0.61800 | 6.5 |
| K0S | 5.20080 | 3.34880 | 2.33070 | 1.85570 | 0.77920 | 0.68960 | 0.63670 | 6.7 |

6.3.7 Type V 090 – Standard bevel gearboxes

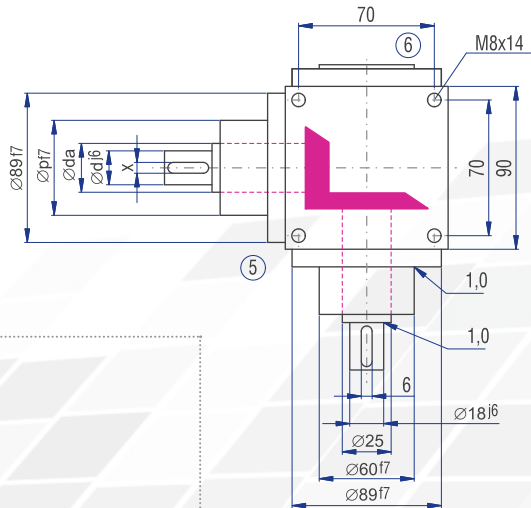
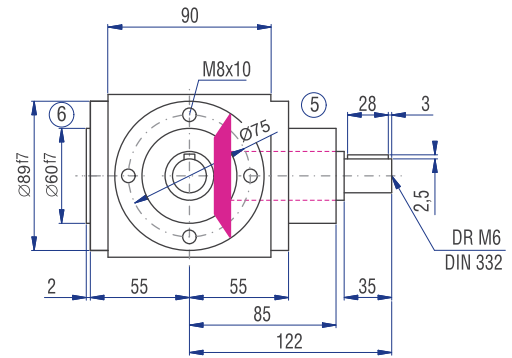
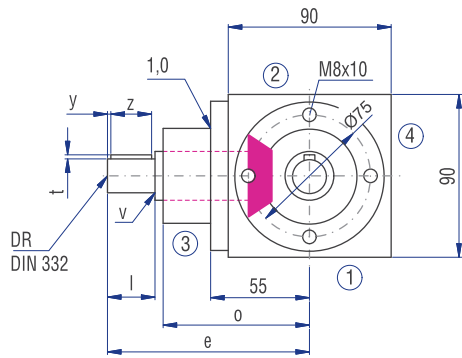
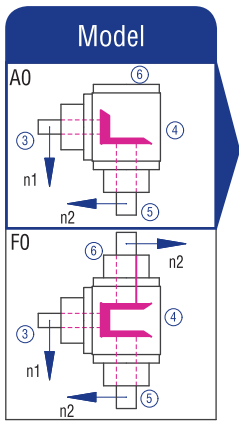

| | Gear ratio | | | | | | |
|---------|------------|-------|-----|-----|-----|-----|-----|
| | 1:1 | 1.5:1 | 2:1 | 3:1 | 4:1 | 5:1 | 6:1 |
| d [mm] | 18 | 18 | 18 | 12 | 12 | 12 | 12 |
| da [mm] | 25 | 25 | 25 | 20 | 20 | 20 | 20 |
| l [mm] | 35 | 35 | 35 | 35 | 35 | 35 | 35 |
| v [mm] | 1 | 1 | 1 | 0.5 | 0.5 | 0.5 | 0.5 |
| x [mm] | 6 | 6 | 6 | 4 | 4 | 4 | 4 |
| y [mm] | 3 | 3 | 3 | 3 | 3 | 3 | 3 |
| z [mm] | 28 | 28 | 28 | 28 | 28 | 28 | 28 |
| t [mm] | 2.5 | 2.5 | 2.5 | 1.5 | 1.5 | 1.5 | 1.5 |
| e [mm] | 122 | 122 | 122 | 122 | 132 | 132 | 132 |
| o [mm] | 85 | 85 | 85 | 85 | 95 | 95 | 95 |
| p [mm] | 60 | 60 | 60 | 60 | 60 | 60 | 60 |
| DR M | 6 | 6 | 6 | 4 | 4 | 4 | 4 |

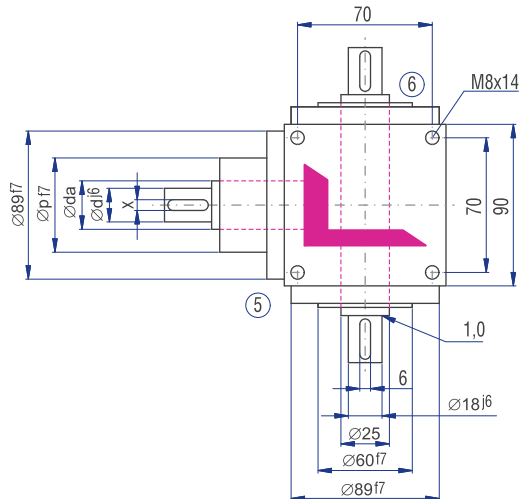
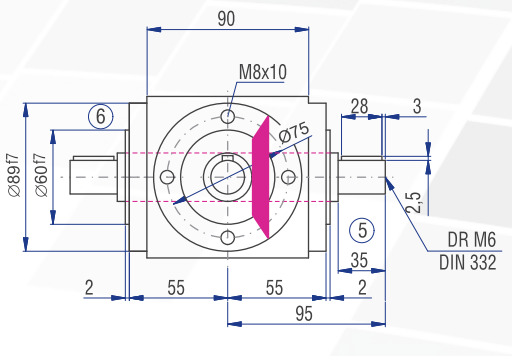
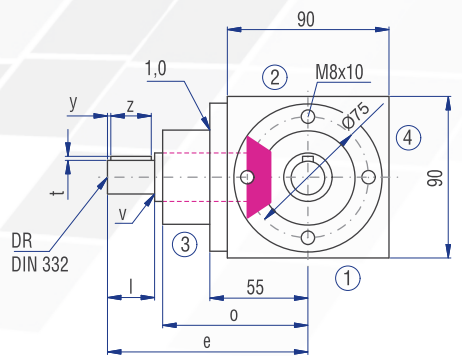
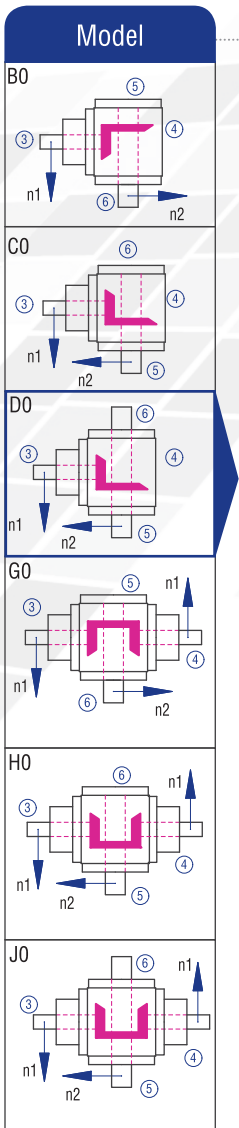

Implementation VV

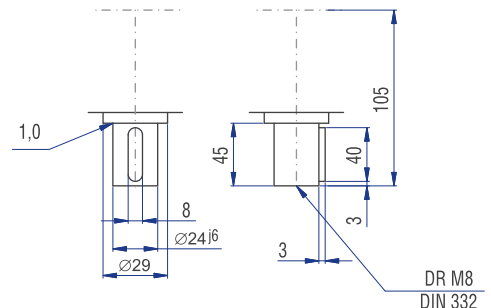

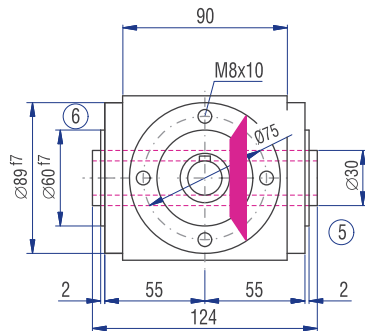
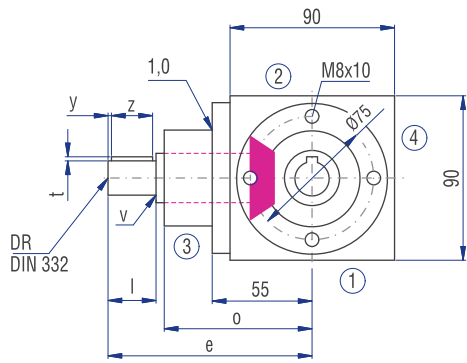

Implementation

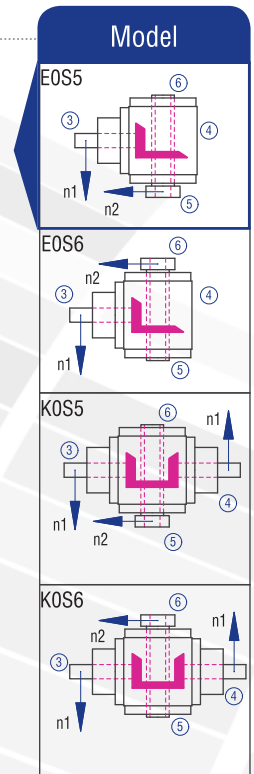
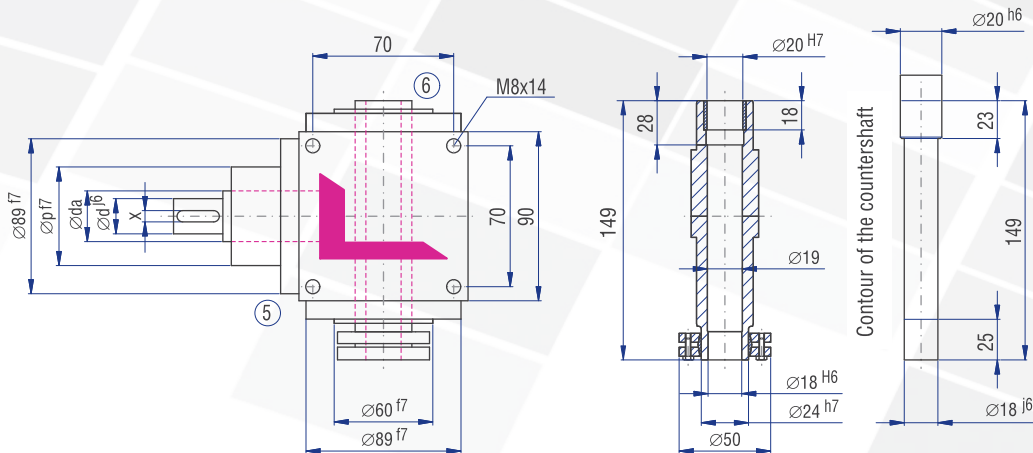
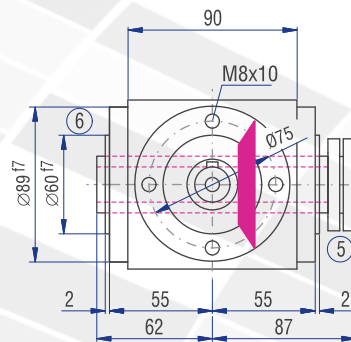
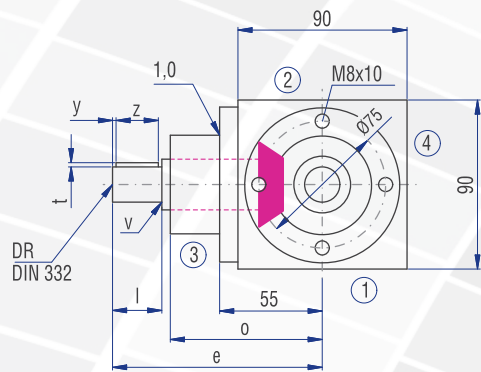
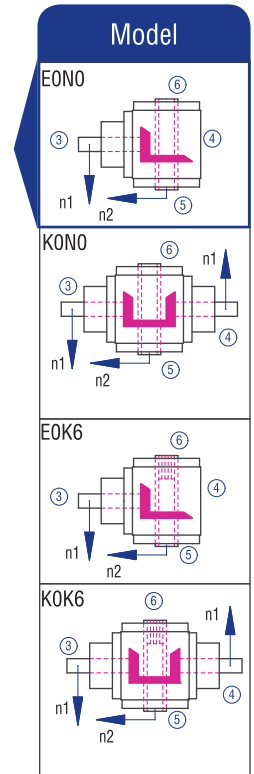
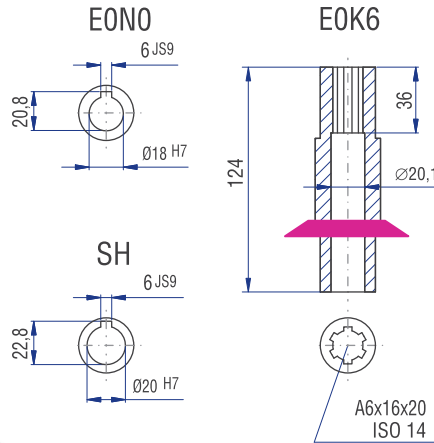
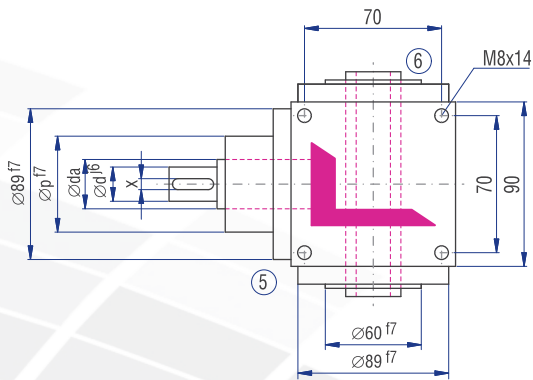

6.3.8 Type V 120 – Standard bevel gearboxes

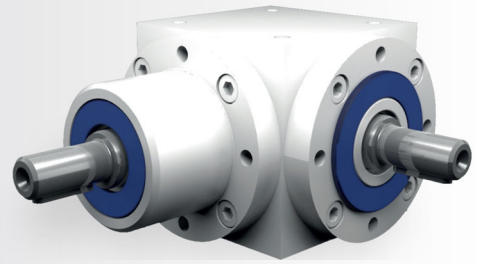

Characteristics

| Characteristic | Standard | Option |
|---------------------------------|--|--------------------|
| Toothing | Spiral toothed bevel gear set | See chapter 6.2.1 |
| Gear ratio | 1:1 to 6:1 | |
| Housing / Flanges | Grey cast iron; steel | |
| Threaded mounting hole | On all housing surfaces without flange and on all flanges. | See chapter 6.2.3 |
| Shaft | Material 1 C45, shaft ends greased Fit with ISO 6 tolerance with parallel keyway: according to DIN 6885 Sheet 1 | See chapter 4.6.2 |
| Hollow shaft | Material 1 C45, shafts greased Fit with ISO 7 tolerance with parallel keyway: according to DIN 6885 Sheet 1 | See chapter 4.6.3 |
| Radial shaft seal ring | NBR, form A | See chapter 4.8 |
| Ambient temperature | -10°C to +90°C. The values of the performance tables are valid for +20°C | See chapter 4.9.3 |
| Circumferential backlash | < 30 arcmin | See chapter 6.2.10 |
| Protection class | IP 54 | See chapter 4.5 |
| Corrosion protection | Prime coat; layer thickness > 40 µm | See chapter 4.4.1 |
| Bearing life L10h | more than 15,000h | See chapter 4.9.1 |
| Oil change intervals | Not required if the oil temperature is kept < 90°C The lifetime of the bearings can be increased by the factor 1.5 if the oil is changed after the first 500 service hours and then every 5000 service hours. | See chapter 6.2.8 |
| Lubricant | Synthetic lubricants | See chapter 6.2.8 |

Performance data

| n_1 [rpm] | 1:1 | | | 1.5:1 | | | 2:1 | | | 3:1 | | | 4:1 | | | 5:1 | | | 6:1 | | |
|----------------|----------------|------------------|------------------|----------------|------------------|------------------|----------------|------------------|------------------|----------------|------------------|------------------|----------------|------------------|------------------|----------------|------------------|------------------|----------------|------------------|------------------|
| | n_2 [rpm] | P_{1N} [kW] | T_{2N} [Nm] | n_2 [rpm] | P_{1N} [kW] | T_{2N} [Nm] | n_2 [rpm] | P_{1N} [kW] | T_{2N} [Nm] | n_2 [rpm] | P_{1N} [kW] | T_{2N} [Nm] | n_2 [rpm] | P_{1N} [kW] | T_{2N} [Nm] | n_2 [rpm] | P_{1N} [kW] | T_{2N} [Nm] | n_2 [rpm] | P_{1N} [kW] | T_{2N} [Nm] |
| 3000 | 3000 | 21.82 | 66 | 2000 | 13.45 | 61 | 1500 | 9.26 | 56 | 1000 | 6.39 | 58 | 750 | 4.96 | 60 | 600 | 3.97 | 60 | 500 | 2.95 | 54 |
| 2400 | 2400 | 18.52 | 70 | 1600 | 11.46 | 65 | 1200 | 8.07 | 61 | 800 | 5.56 | 63 | 600 | 4.43 | 67 | 480 | 3.44 | 65 | 400 | 2.53 | 57 |
| 1500 | 1500 | 13.56 | 82 | 1000 | 8.60 | 78 | 750 | 6.03 | 73 | 500 | 4.08 | 74 | 375 | 3.06 | 74 | 300 | 2.38 | 72 | 250 | 1.75 | 64 |
| 1000 | 1000 | 10.14 | 92 | 667 | 6.32 | 86 | 500 | 4.46 | 81 | 333 | 3.01 | 82 | 250 | 2.18 | 79 | 200 | 1.76 | 80 | 167 | 1.22 | 66 |
| 750 | 750 | 8.51 | 103 | 500 | 5.18 | 94 | 375 | 3.55 | 86 | 250 | 2.40 | 87 | 188 | 1.69 | 82 | 150 | 1.42 | 86 | 125 | 0.94 | 68 |
| 500 | 500 | 6.34 | 115 | 333 | 3.85 | 100 | 250 | 2.54 | 92 | 167 | 1.66 | 90 | 125 | 1.16 | 84 | 100 | 0.98 | 89 | 83 | 0.63 | 69 |
| 250 | 250 | 3.39 | 123 | 167 | 1.99 | 100 | 125 | 1.35 | 98 | 83 | 0.87 | 95 | 63 | 0.60 | 87 | 50 | 0.51 | 92 | 42 | 0.33 | 71 |
| 50 | 50 | 0.72 | 130 | 33 | 0.41 | 100 | 25 | 0.29 | 107 | 17 | 0.21 | 110 | 13 | 0.12 | 90 | 10 | 0.10 | 95 | 8 | 0.06 | 66 |

| | | | | | | | | | | | | | | | | | | | | | | |
|-----------------|-----|-----|-----|-----|-----|-----|-----|-----|-----|-----|-----|-----|-----|-----|-----|-----|-----|-----|-----|-----|-----|-----|
| P_{1Nt} [kW] | 6.2 | 6.2 | 6.2 | 6.2 | 6.2 | 6.2 | 6.2 | 6.2 | 6.2 | 6.2 | 6.2 | 6.2 | 6.2 | 6.2 | 6.2 | 6.2 | 6.2 | 6.2 | 6.2 | 6.2 | 6.2 | 6.2 |
| T_{2max} [Nm] | 220 | 169 | 169 | 169 | 169 | 169 | 169 | 169 | 169 | 169 | 169 | 169 | 169 | 169 | 169 | 169 | 169 | 169 | 169 | 169 | 169 | 169 |

Permissible radial force F_{r1} and axial force F_{a1} on shaft N_1

| n_1 [rpm] | 3000 | | 1000 | | 500 | | 250 | | 100 | | 50 | |
|-------------|-----------|-----------|-----------|-----------|-----------|-----------|-----------|-----------|-----------|-----------|-----------|-----------|
| T_2 [Nm] | F_r [N] | F_a [N] | F_r [N] | F_a [N] | F_r [N] | F_a [N] | F_r [N] | F_a [N] | F_r [N] | F_a [N] | F_r [N] | F_a [N] |
| < 80 | 470 | 235 | 620 | 310 | 720 | 360 | 900 | 450 | 1150 | 575 | 1400 | 700 |
| > 80 | 390 | 195 | 520 | 260 | 600 | 300 | 750 | 375 | 960 | 480 | 1170 | 585 |

Permissible radial force F_{r2} and axial force F_{a2} on shaft N_2

| n_2 [rpm] | 3000 | | 1000 | | 500 | | 250 | | 100 | | 50 | |
|-------------|-----------|-----------|-----------|-----------|-----------|-----------|-----------|-----------|-----------|-----------|-----------|-----------|
| T_2 [Nm] | F_r [N] | F_a [N] | F_r [N] | F_a [N] | F_r [N] | F_a [N] | F_r [N] | F_a [N] | F_r [N] | F_a [N] | F_r [N] | F_a [N] |
| < 80 | 750 | 375 | 1000 | 500 | 1250 | 625 | 1500 | 750 | 1900 | 950 | 2200 | 1100 |
| > 80 | 630 | 315 | 830 | 415 | 1040 | 520 | 1250 | 625 | 1580 | 790 | 1830 | 915 |

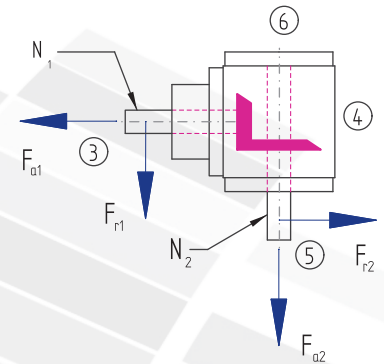

Inertia moments/mass

Inertia moment J_1 related to the fast-rotating shaft (N_1)

| Model | Inertia moment [kgcm ²] | | | | | | | Mass [kg] |
|-------|-------------------------------------|---------|---------|---------|---------|---------|---------|-----------|
| | 1:1 | 1.5:1 | 2:1 | 3:1 | 4:1 | 5:1 | 6:1 | |
| A0 | 10.4976 | 4.84090 | 3.64650 | 2.31590 | 1.21640 | 0.75160 | 0.67660 | 12.6 |
| B0 | 15.3022 | 7.44410 | 4.97470 | 3.01230 | 1.67290 | 1.05930 | 0.89820 | 12.3 |
| C0 | 15.3022 | 7.44410 | 4.97470 | 3.01230 | 1.67290 | 1.05930 | 0.89820 | 12.3 |
| D0 | 15.5996 | 7.57620 | 5.04900 | 3.04530 | 1.69150 | 1.07120 | 0.90650 | 12.5 |
| E0N | 15.1939 | 7.39590 | 4.94760 | 3.00030 | 1.66610 | 1.05500 | 0.89520 | 12.0 |
| E0S | 16.9812 | 8.19030 | 5.39440 | 3.19880 | 1.77780 | 1.12650 | 0.94490 | 12.3 |
| F0 | 15.7464 | 7.17370 | 4.95870 | 2.89910 | 1.54440 | 0.96150 | 0.82240 | 15.0 |
| G0 | 20.5510 | 9.95220 | 7.30900 | 4.74500 | 2.56120 | 1.60090 | 1.42900 | 14.7 |
| H0 | 20.5510 | 9.95220 | 7.30900 | 4.74500 | 2.56120 | 1.60090 | 1.42900 | 14.7 |
| J0 | 20.8484 | 10.0843 | 7.38330 | 4.77800 | 2.57980 | 1.61280 | 1.43730 | 14.9 |
| K0N | 20.4427 | 9.90400 | 7.28190 | 4.73300 | 2.55440 | 1.59660 | 1.42600 | 14.4 |
| K0S | 22.2300 | 10.6984 | 7.72870 | 4.93150 | 2.66610 | 1.66810 | 1.47570 | 14.7 |

6.3.8 Type V 120 – Standard bevel gearboxes

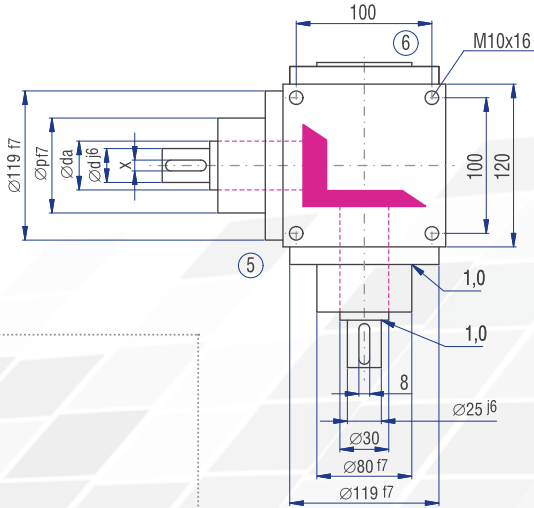
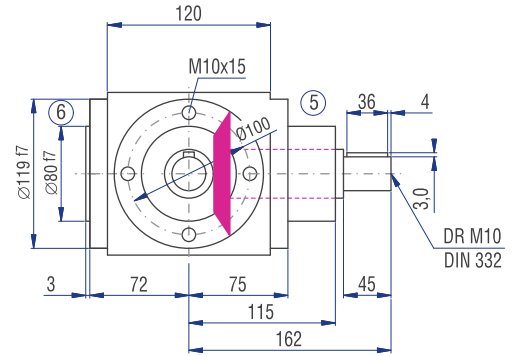
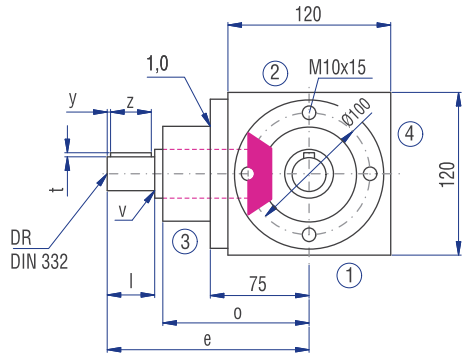
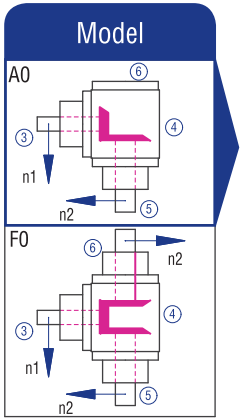

| | Gear ratio | | | | | | |
|---------|------------|-------|-----|-----|-----|-----|-----|
| | 1:1 | 1.5:1 | 2:1 | 3:1 | 4:1 | 5:1 | 6:1 |
| d [mm] | 25 | 25 | 25 | 20 | 20 | 15 | 15 |
| da [mm] | 30 | 30 | 30 | 25 | 25 | 20 | 20 |
| l [mm] | 45 | 45 | 45 | 45 | 45 | 35 | 35 |
| v [mm] | 1 | 1 | 1 | 1 | 1 | 0.5 | 0.5 |
| x [mm] | 8 | 8 | 8 | 6 | 6 | 5 | 5 |
| y [mm] | 4 | 4 | 4 | 4 | 4 | 4 | 4 |
| z [mm] | 36 | 36 | 36 | 36 | 36 | 28 | 28 |
| t [mm] | 3 | 3 | 3 | 2.5 | 2.5 | 2 | 2 |
| e [mm] | 162 | 162 | 162 | 162 | 172 | 162 | 162 |
| o [mm] | 115 | 115 | 115 | 115 | 125 | 125 | 125 |
| p [mm] | 80 | 80 | 80 | 80 | 80 | 70 | 70 |
| DR M | 10 | 10 | 10 | 6 | 6 | 5 | 5 |

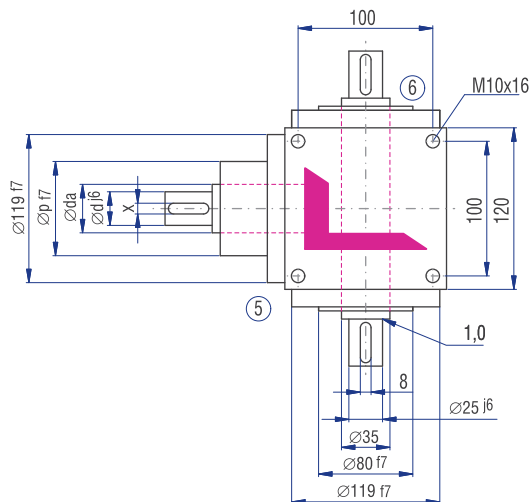
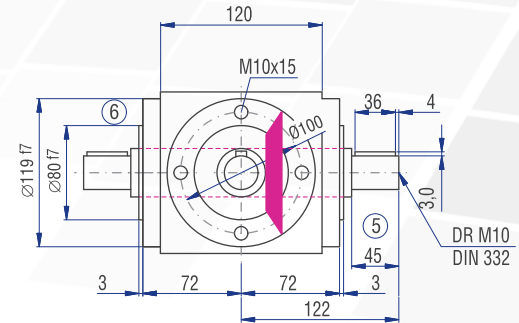
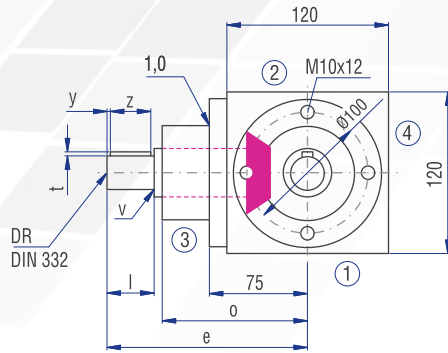
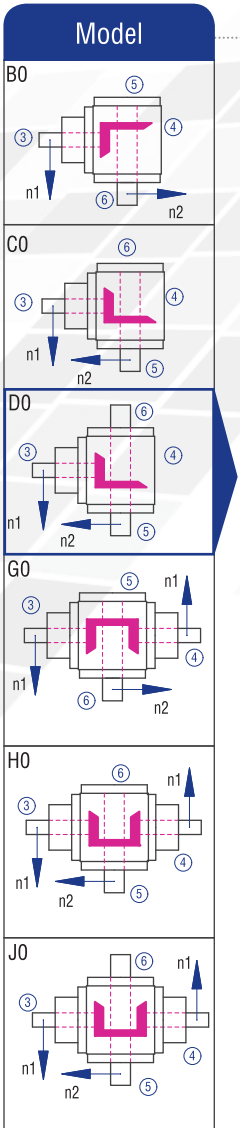

Implementation VV

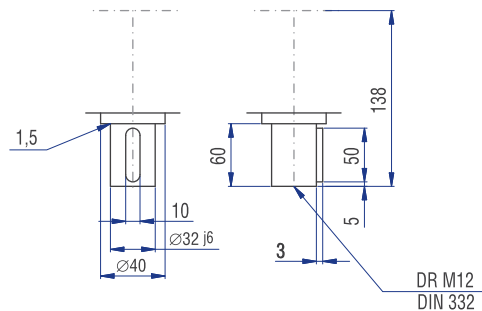

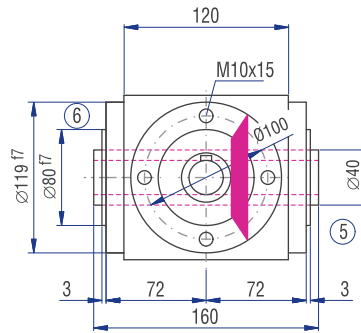
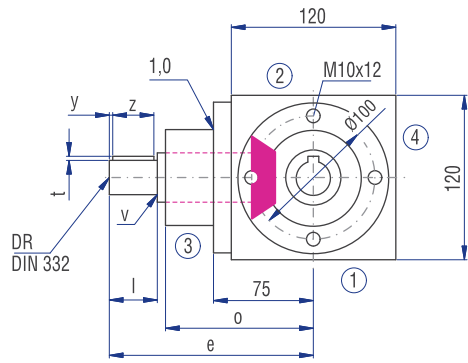

Implementation

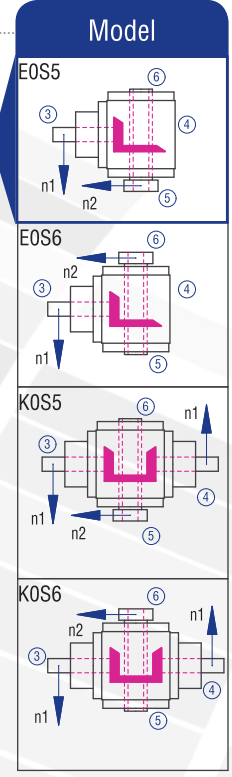
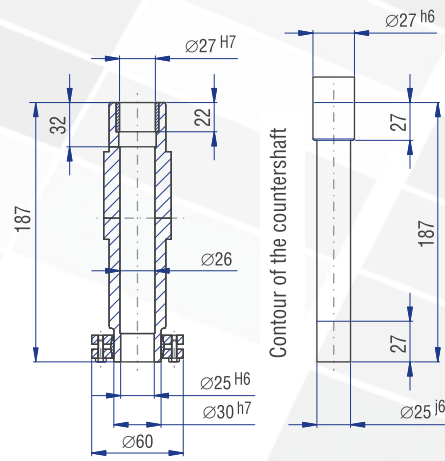
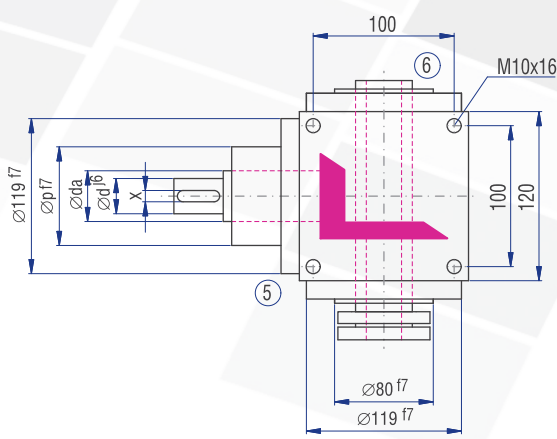
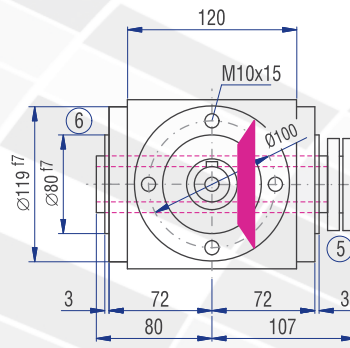
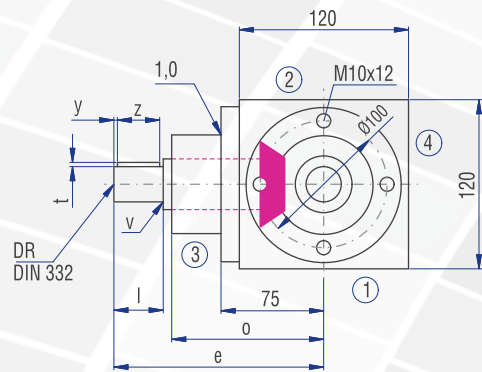
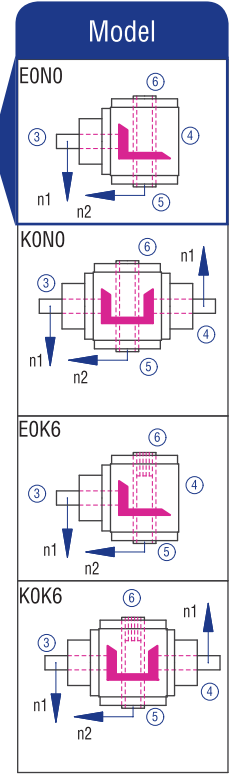
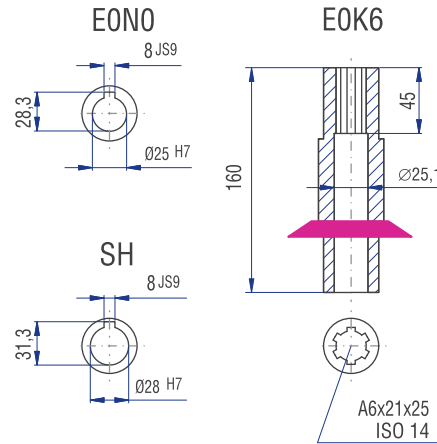
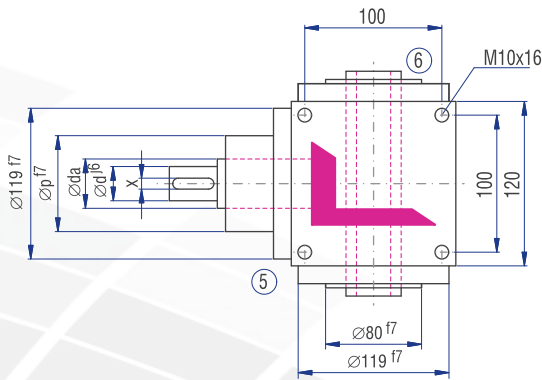

6.3.9 Type V 140 – Standard bevel gearboxes

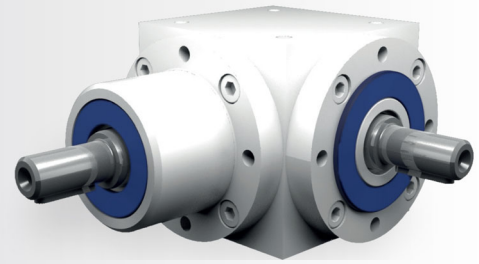

Characteristics

| Characteristic | Standard | Option |
|---------------------------------|--|--------------------|
| Toothing | Spiral toothed bevel gear set | See chapter 6.2.1 |
| Gear ratio | 1:1 to 6:1 | |
| Housing / Flanges | Grey cast iron; steel | |
| Threaded mounting hole | On all housing surfaces without flange and on all flanges. | See chapter 6.2.3 |
| Shaft | Material 1 C45, shaft ends greased Fit with ISO 6 tolerance with parallel keyway: according to DIN 6885 Sheet 1 | See chapter 4.6.2 |
| Hollow shaft | Material 1 C45, shafts greased Fit with ISO 7 tolerance with parallel keyway: according to DIN 6885 Sheet 1 | See chapter 4.6.3 |
| Radial shaft seal ring | NBR, form A | See chapter 4.8 |
| Ambient temperature | -10°C to +90°C. The values of the performance tables are valid for +20°C | See chapter 4.9.3 |
| Circumferential backlash | < 30 arcmin | See chapter 6.2.10 |
| Protection class | IP 54 | See chapter 4.5 |
| Corrosion protection | Prime coat; layer thickness > 40 µm | See chapter 4.4.1 |
| Bearing life L10h | more than 15,000h | See chapter 4.9.1 |
| Oil change intervals | Not required if the oil temperature is kept < 90°C The lifetime of the bearings can be increased by the factor 1.5 if the oil is changed after the first 500 service hours and then every 5000 service hours. | See chapter 6.2.8 |
| Lubricant | Synthetic lubricants | See chapter 6.2.8 |

Performance data

| n_1 [rpm] | 1:1 | | 1.5:1 | | | 2:1 | | | 3:1 | | | 4:1 | | | 5:1 | | | 6:1 | | | |
|----------------|----------------|------------------|------------------|----------------|------------------|------------------|----------------|------------------|------------------|----------------|------------------|------------------|----------------|------------------|------------------|----------------|------------------|------------------|----------------|------------------|------------------|
| | n_2 [rpm] | P_{1N} [kW] | T_{2N} [Nm] | n_2 [rpm] | P_{1N} [kW] | T_{2N} [Nm] | n_2 [rpm] | P_{1N} [kW] | T_{2N} [Nm] | n_2 [rpm] | P_{1N} [kW] | T_{2N} [Nm] | n_2 [rpm] | P_{1N} [kW] | T_{2N} [Nm] | n_2 [rpm] | P_{1N} [kW] | T_{2N} [Nm] | n_2 [rpm] | P_{1N} [kW] | T_{2N} [Nm] |
| 3000 | 3000 | 39.68 | 120 | 2000 | 24.91 | 113 | 1500 | 16.53 | 100 | 1000 | 12.12 | 110 | 750 | 8.51 | 103 | 600 | 6.61 | 100 | 500 | 5.18 | 94 |
| 2400 | 2400 | 37.04 | 140 | 1600 | 22.22 | 126 | 1200 | 14.68 | 111 | 800 | 11.46 | 130 | 600 | 7.34 | 111 | 480 | 5.56 | 105 | 400 | 4.58 | 104 |
| 1500 | 1500 | 26.78 | 162 | 1000 | 17.08 | 155 | 750 | 11.41 | 138 | 500 | 8.05 | 146 | 375 | 4.96 | 120 | 300 | 3.80 | 115 | 250 | 2.95 | 107 |
| 1000 | 1000 | 20.28 | 184 | 667 | 12.87 | 175 | 500 | 8.38 | 152 | 333 | 5.87 | 160 | 250 | 3.75 | 136 | 200 | 2.73 | 124 | 167 | 2.06 | 112 |
| 750 | 750 | 16.20 | 196 | 500 | 10.47 | 190 | 375 | 6.86 | 166 | 250 | 4.60 | 167 | 188 | 3.06 | 148 | 150 | 2.15 | 130 | 125 | 1.61 | 117 |
| 500 | 500 | 11.46 | 208 | 333 | 7.34 | 200 | 250 | 4.96 | 180 | 167 | 3.20 | 174 | 125 | 2.12 | 154 | 100 | 1.50 | 136 | 83 | 1.09 | 119 |
| 250 | 250 | 5.92 | 215 | 167 | 3.76 | 204 | 125 | 2.62 | 190 | 83 | 1.62 | 177 | 63 | 1.12 | 162 | 50 | 0.79 | 143 | 42 | 0.56 | 121 |
| 50 | 50 | 1.21 | 220 | 33 | 0.76 | 210 | 25 | 0.55 | 200 | 17 | 0.34 | 180 | 13 | 0.23 | 170 | 10 | 0.17 | 150 | 8 | 0.11 | 120 |

| | | | | | | | |
|-----------------|------|------|------|------|------|------|------|
| P_{1Nt} [kW] | 10.0 | 10.0 | 10.0 | 10.0 | 10.0 | 10.0 | 10.0 |
| T_{2max} [Nm] | 430 | 358 | 320 | 280 | 280 | 250 | 200 |

Permissible radial force F_{r1} and axial force F_{a1} on shaft N_1

| n_1 [rpm] | 3000 | | 1000 | | 500 | | 250 | | 100 | | 50 | |
|-------------|-----------|-----------|-----------|-----------|-----------|-----------|-----------|-----------|-----------|-----------|-----------|-----------|
| T_2 [Nm] | F_r [N] | F_a [N] | F_r [N] | F_a [N] | F_r [N] | F_a [N] | F_r [N] | F_a [N] | F_r [N] | F_a [N] | F_r [N] | F_a [N] |
| < 140 | 700 | 350 | 870 | 435 | 1150 | 575 | 1370 | 685 | 1700 | 850 | 2000 | 1000 |
| > 140 | 590 | 295 | 730 | 365 | 960 | 480 | 1140 | 570 | 1420 | 710 | 1670 | 835 |

Permissible radial force F_{r2} and axial force F_{a2} on shaft N_2

| n_2 [rpm] | 3000 | | 1000 | | 500 | | 250 | | 100 | | 50 | |
|-------------|-----------|-----------|-----------|-----------|-----------|-----------|-----------|-----------|-----------|-----------|-----------|-----------|
| T_2 [Nm] | F_r [N] | F_a [N] | F_r [N] | F_a [N] | F_r [N] | F_a [N] | F_r [N] | F_a [N] | F_r [N] | F_a [N] | F_r [N] | F_a [N] |
| < 140 | 1300 | 650 | 1700 | 850 | 2000 | 1000 | 2500 | 1250 | 3000 | 1500 | 3800 | 1900 |
| > 140 | 1082 | 541 | 1420 | 710 | 1670 | 835 | 2080 | 1040 | 2500 | 1250 | 3170 | 1585 |

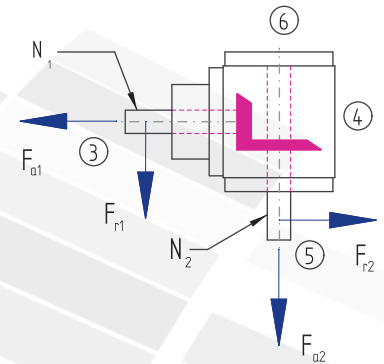

Inertia moments/mass

Inertia moment J_1 related to the fast-rotating shaft (N_1)

| Model | Inertia moment [kgcm ²] | | | | | | | Mass [kg] |
|-------|-------------------------------------|---------|---------|---------|---------|---------|---------|-----------|
| | 1:1 | 1.5:1 | 2:1 | 3:1 | 4:1 | 5:1 | 6:1 | |
| A0 | 26.2670 | 11.8569 | 8.6762 | 6.43560 | 1.84320 | 1.53200 | 1.37080 | 19.0 |
| B0 | 36.0994 | 18.7513 | 12.2785 | 7.95470 | 2.69780 | 2.21130 | 1.84260 | 18.5 |
| C0 | 36.0994 | 18.7513 | 12.2785 | 7.95470 | 2.69780 | 2.21130 | 1.84260 | 18.5 |
| D0 | 37.0815 | 19.1878 | 12.5241 | 8.06390 | 2.75920 | 2.25060 | 1.86980 | 19.0 |
| E0N | 32.6630 | 17.2240 | 11.4194 | 7.57290 | 2.48300 | 2.07390 | 1.74710 | 18.0 |
| E0S | 39.0643 | 20.0691 | 13.0198 | 8.28420 | 2.88310 | 2.32990 | 1.92490 | 18.7 |
| F0 | 39.4005 | 17.6940 | 11.9596 | 7.89490 | 2.66410 | 2.05740 | 1.73560 | 23.0 |
| G0 | 49.2329 | 24.7711 | 17.6713 | 12.9310 | 3.72020 | 3.21800 | 2.84860 | 22.7 |
| H0 | 49.2329 | 24.7711 | 17.6713 | 12.9310 | 3.72020 | 3.21800 | 2.84860 | 22.7 |
| J0 | 50.2150 | 25.2076 | 17.9169 | 13.0402 | 3.78160 | 3.25730 | 2.87580 | 23.2 |
| K0N | 45.7965 | 23.2438 | 16.8122 | 12.5492 | 3.50540 | 3.08060 | 2.75310 | 22.2 |
| K0S | 52.1978 | 26.0889 | 18.4126 | 13.2605 | 3.90550 | 3.33660 | 2.93090 | 22.9 |

6.3.9 Type V 140 – Standard bevel gearboxes

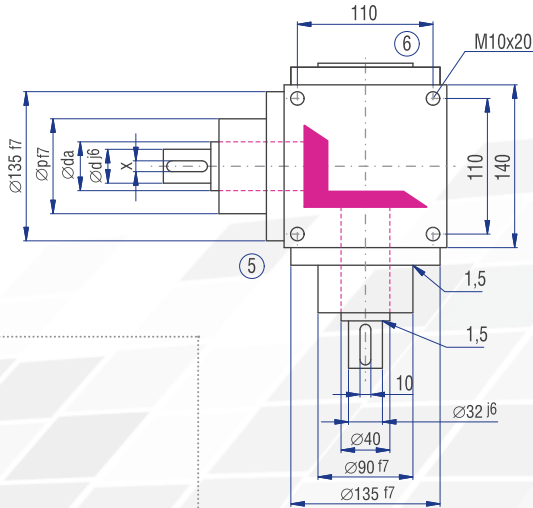
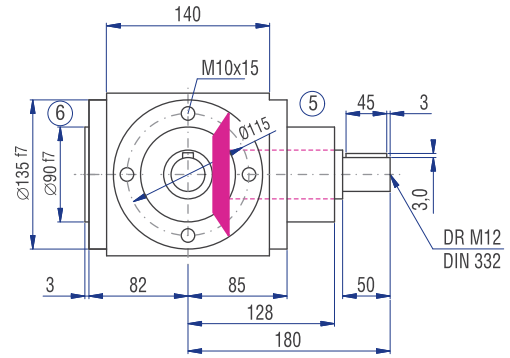
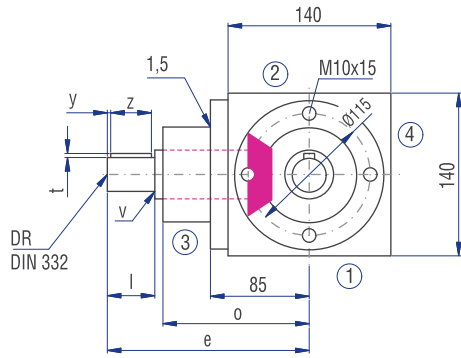
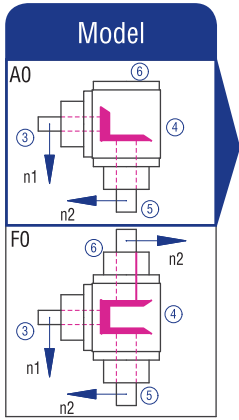

| | Gear ratio | | | | | | |
|---------|------------|-------|-----|-----|-----|-----|-----|
| | 1:1 | 1.5:1 | 2:1 | 3:1 | 4:1 | 5:1 | 6:1 |
| d [mm] | 32 | 32 | 32 | 28 | 24 | 24 | 24 |
| da [mm] | 40 | 40 | 40 | 40 | 40 | 40 | 40 |
| l [mm] | 50 | 50 | 50 | 50 | 50 | 50 | 50 |
| v [mm] | 1.5 | 1.5 | 1.5 | 1 | 1 | 1 | 1 |
| x [mm] | 10 | 10 | 10 | 8 | 8 | 8 | 8 |
| y [mm] | 3 | 3 | 3 | 3 | 3 | 3 | 3 |
| z [mm] | 45 | 45 | 45 | 45 | 45 | 45 | 45 |
| t [mm] | 3 | 3 | 3 | 3 | 3 | 3 | 3 |
| e [mm] | 180 | 180 | 180 | 180 | 195 | 195 | 195 |
| o [mm] | 128 | 128 | 128 | 128 | 143 | 143 | 143 |
| p [mm] | 90 | 90 | 90 | 90 | 85 | 85 | 85 |
| DR M | 12 | 12 | 12 | 10 | 8 | 8 | 8 |

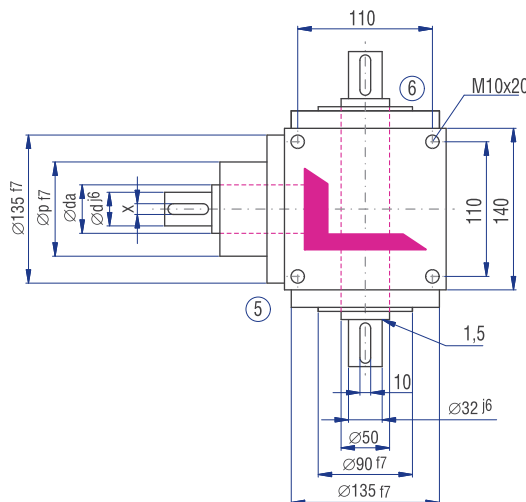
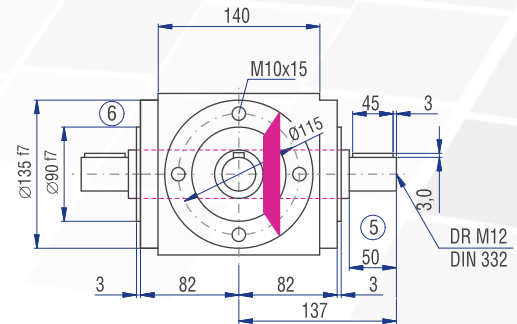
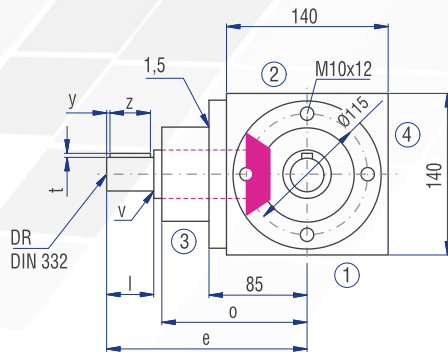
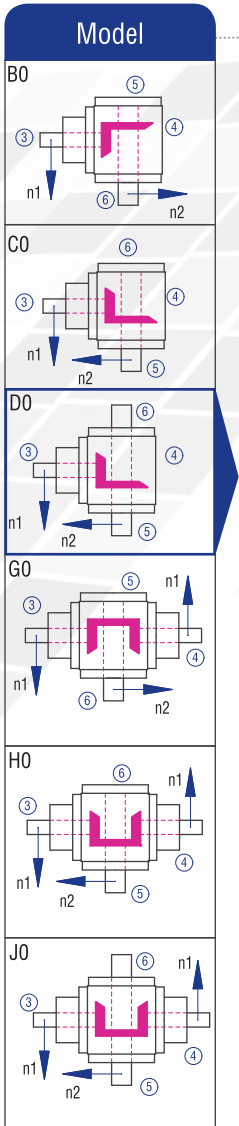

Implementation VV

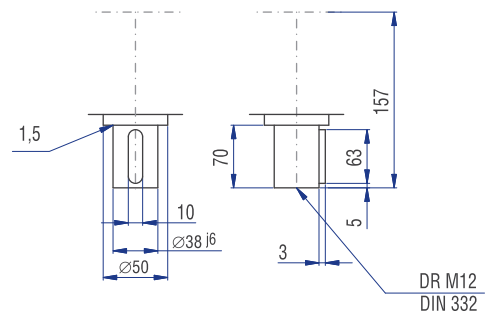

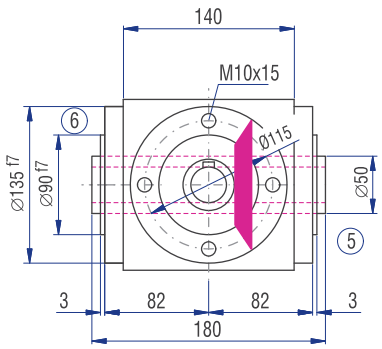
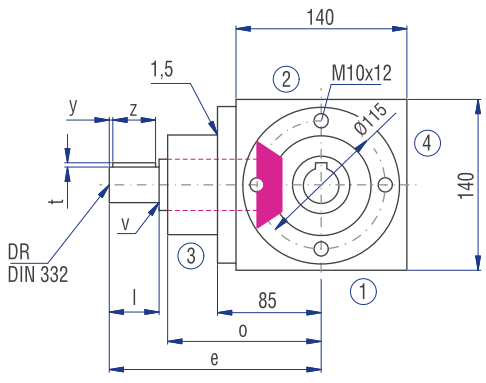

Implementation

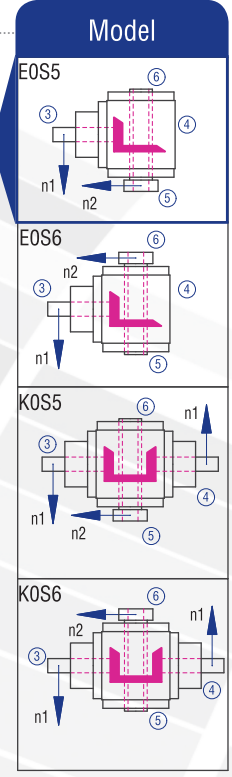
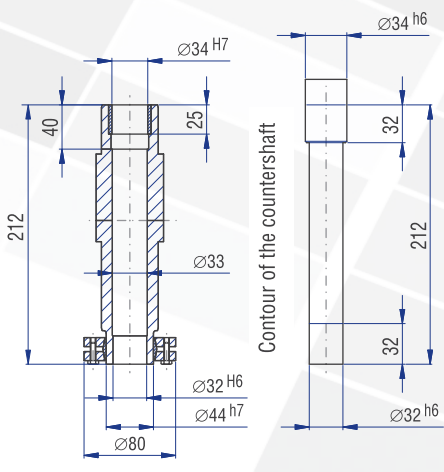
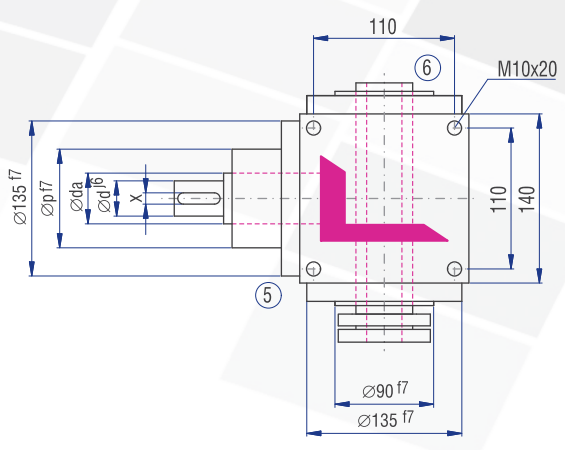
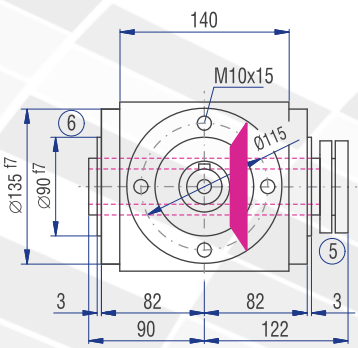
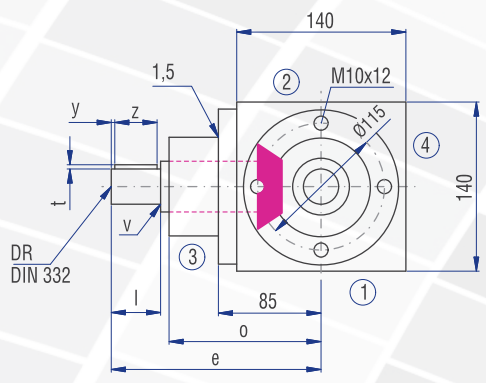
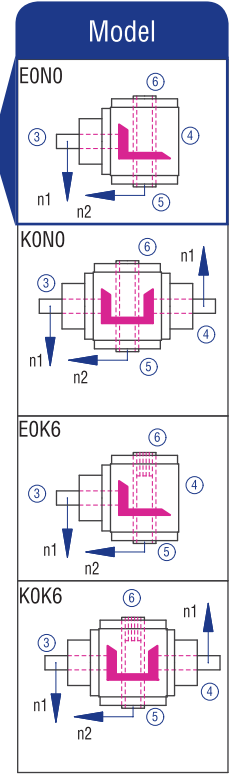
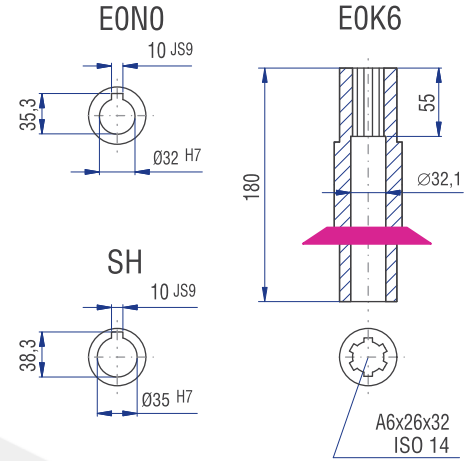
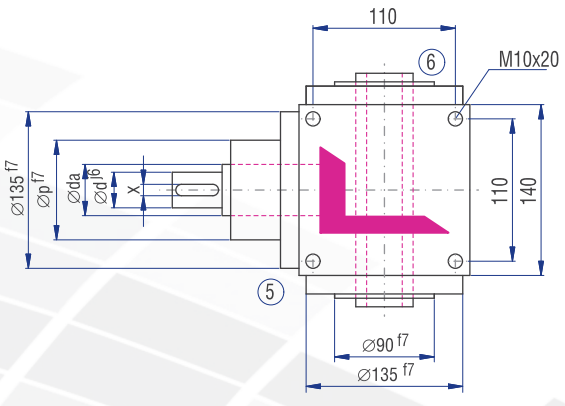

6.3.10 Type V 160 – Standard bevel gearboxes

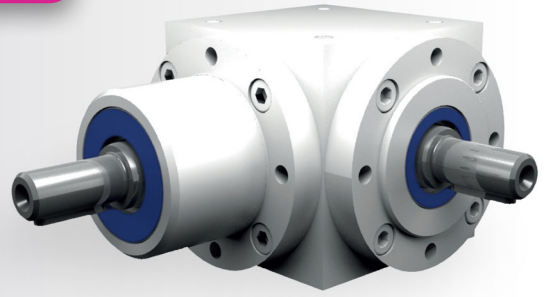

Characteristics

| Characteristic | Standard | Option |
|---------------------------------|--|--------------------|
| Toothing | Spiral toothed bevel gear set | See chapter 6.2.1 |
| Gear ratio | 1:1 to 6:1 | |
| Housing / Flanges | Grey cast iron; steel | |
| Threaded mounting hole | On all housing surfaces without flange and on all flanges. | See chapter 6.2.3 |
| Shaft | Material 1 C45, shaft ends greased Fit with ISO 6 tolerance with parallel keyway: according to DIN 6885 Sheet 1 | See chapter 4.6.2 |
| Hollow shaft | Material 1 C45, shafts greased Fit with ISO 7 tolerance with parallel keyway: according to DIN 6885 Sheet 1 | See chapter 4.6.3 |
| Radial shaft seal ring | NBR, form A | See chapter 4.8 |
| Ambient temperature | -10°C to +90°C. The values of the performance tables are valid for +20°C | See chapter 4.9.3 |
| Circumferential backlash | < 30 arcmin | See chapter 6.2.10 |
| Protection class | IP 54 | See chapter 4.5 |
| Corrosion protection | Prime coat; layer thickness > 40 µm | See chapter 4.4.1 |
| Bearing life L10h | more than 15,000h | See chapter 4.9.1 |
| Oil change intervals | Not required if the oil temperature is kept < 90°C The lifetime of the bearings can be increased by the factor 1.5 if the oil is changed after the first 500 service hours and then every 5000 service hours. | See chapter 6.2.8 |
| Lubricant | Synthetic lubricants | See chapter 6.2.8 |

Performance data

| n ₁ [rpm] | 1:1 | | | 1.5:1 | | | 2:1 | | | 3:1 | | | 4:1 | | | 5:1 | | | 6:1 | | | | | |
|-------------------------|-------------------------|-------------------------|-------------------------|-------------------------|-------------------------|-------------------------|-------------------------|-------------------------|-------------------------|-------------------------|-------------------------|-------------------------|-------------------------|-------------------------|-------------------------|-------------------------|-------------------------|-------------------------|-------------------------|-------------------------|-------------------------|--|--|--|
| | n ₂ [rpm] | P _{1N} [kW] | T _{2N} [Nm] | n ₂ [rpm] | P _{1N} [kW] | T _{2N} [Nm] | n ₂ [rpm] | P _{1N} [kW] | T _{2N} [Nm] | n ₂ [rpm] | P _{1N} [kW] | T _{2N} [Nm] | n ₂ [rpm] | P _{1N} [kW] | T _{2N} [Nm] | n ₂ [rpm] | P _{1N} [kW] | T _{2N} [Nm] | n ₂ [rpm] | P _{1N} [kW] | T _{2N} [Nm] | | | |
| 3000 | | | | 2000 | 40.78 | 185 | 1500 | 28.11 | 170 | 1000 | 20.94 | 190 | 750 | 14.88 | 180 | 600 | 11.90 | 180 | 500 | 7.09 | 129 | | | |
| 2400 | 2400 | 57.67 | 218 | 1600 | 36.15 | 205 | 1200 | 25.53 | 193 | 800 | 17.81 | 202 | 600 | 13.23 | 200 | 480 | 10.48 | 198 | 400 | 5.98 | 136 | | | |
| 1500 | 1500 | 42.99 | 260 | 1000 | 27.78 | 252 | 750 | 20.25 | 245 | 500 | 12.68 | 230 | 375 | 9.09 | 220 | 300 | 7.11 | 215 | 250 | 3.95 | 143 | | | |
| 1000 | 1000 | 31.96 | 290 | 667 | 20.59 | 280 | 500 | 14.88 | 270 | 333 | 8.99 | 245 | 250 | 6.61 | 240 | 200 | 4.96 | 225 | 167 | 3.01 | 164 | | | |
| 750 | 750 | 25.63 | 310 | 500 | 16.26 | 295 | 375 | 11.57 | 280 | 250 | 6.89 | 250 | 188 | 5.17 | 250 | 150 | 3.97 | 240 | 125 | 2.43 | 176 | | | |
| 500 | 500 | 18.19 | 330 | 333 | 11.56 | 315 | 250 | 8.27 | 300 | 167 | 4.79 | 260 | 125 | 3.58 | 260 | 100 | 2.76 | 250 | 83 | 1.72 | 187 | | | |
| 250 | 250 | 9.64 | 350 | 167 | 6.07 | 330 | 125 | 4.41 | 320 | 83 | 2.56 | 280 | 63 | 1.86 | 270 | 50 | 1.49 | 270 | 42 | 0.92 | 199 | | | |
| 50 | 50 | 2.09 | 380 | 33 | 1.29 | 355 | 25 | 0.98 | 355 | 17 | 0.57 | 305 | 13 | 0.39 | 280 | 10 | 0.32 | 290 | 8 | 0.18 | 197 | | | |
| P _{1Nt} [kW] | 15.0 | | | 15.0 | | | 15.0 | | | 15.0 | | | 15.0 | | | 15.0 | | | 15.0 | | | | | |
| T _{2max} [Nm] | 660 | | | 650 | | | 650 | | | 457 | | | 422 | | | 420 | | | 350 | | | | | |

Permissible radial force F_{r1} and axial force Fa₁ on shaft N₁

| n ₁ [rpm] | 3000 | | 1000 | | 500 | | 250 | | 100 | | 50 | |
|----------------------|--------------------|--------------------|--------------------|--------------------|--------------------|--------------------|--------------------|--------------------|--------------------|--------------------|--------------------|--------------------|
| T ₂ [Nm] | F _r [N] | F _a [N] | F _r [N] | F _a [N] | F _r [N] | F _a [N] | F _r [N] | F _a [N] | F _r [N] | F _a [N] | F _r [N] | F _a [N] |
| < 220 | 1200 | 600 | 1600 | 800 | 1900 | 950 | 2200 | 1100 | 2850 | 1425 | 3300 | 1650 |
| > 220 | 1000 | 500 | 1340 | 670 | 1590 | 795 | 1840 | 920 | 2380 | 1190 | 2750 | 1375 |

Permissible radial force F_{r2} and axial force Fa₂ on shaft N₂

| n ₂ [rpm] | 3000 | | 1000 | | 500 | | 250 | | 100 | | 50 | |
|----------------------|--------------------|--------------------|--------------------|--------------------|--------------------|--------------------|--------------------|--------------------|--------------------|--------------------|--------------------|--------------------|
| T ₂ [Nm] | F _r [N] | F _a [N] | F _r [N] | F _a [N] | F _r [N] | F _a [N] | F _r [N] | F _a [N] | F _r [N] | F _a [N] | F _r [N] | F _a [N] |
| < 220 | 2000 | 1000 | 2800 | 1400 | 3300 | 1650 | 4000 | 2000 | 5000 | 2500 | 6500 | 3250 |
| > 220 | 1670 | 835 | 2340 | 1170 | 2750 | 1375 | 3340 | 1670 | 4170 | 2085 | 5420 | 2710 |

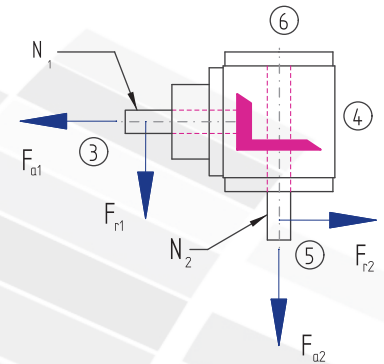

Inertia moments/mass

Inertia moment J₁ related to the fast-rotating shaft (N₁)

| Model | Inertia moment [kgcm ²] | | | | | | | Mass [kg] |
|-------|-------------------------------------|---------|---------|---------|---------|--------|--------|-----------|
| | 1:1 | 1.5:1 | 2:1 | 3:1 | 4:1 | 5:1 | 6:1 | |
| A0 | 29.6710 | 19.6374 | 12.3589 | 8.9516 | 6.4348 | 2.2733 | 2.0901 | 28.5 |
| B0 | 31.5527 | 32.0243 | 20.1006 | 12.0803 | 8.4198 | 3.6887 | 2.9407 | 28.0 |
| C0 | 31.5527 | 32.0243 | 20.1006 | 12.0803 | 8.4198 | 3.6887 | 2.9407 | 28.0 |
| D0 | 32.5820 | 32.4818 | 20.3579 | 12.1947 | 8.4841 | 3.7299 | 2.9693 | 28.5 |
| E0N | 34.3851 | 33.1416 | 20.6658 | 12.3315 | 8.5611 | 3.7791 | 3.0048 | 27.0 |
| E0S | 40.6750 | 35.9371 | 22.2382 | 13.0304 | 8.9542 | 4.0307 | 3.1795 | 27.5 |
| F0 | 44.5065 | 26.2309 | 16.0678 | 10.6000 | 7.3620 | 2.8667 | 2.5022 | 35.0 |
| G0 | 46.3882 | 45.0681 | 28.7506 | 19.3835 | 13.9274 | 5.3686 | 4.6187 | 34.5 |
| H0 | 46.3882 | 45.0681 | 28.7506 | 19.3835 | 13.9274 | 5.3686 | 4.6187 | 34.5 |
| J0 | 47.4175 | 45.5256 | 29.0079 | 19.4979 | 13.9917 | 5.4098 | 4.6473 | 35.0 |
| K0N | 49.2206 | 46.1854 | 29.3158 | 19.6347 | 14.0687 | 5.4590 | 4.6828 | 34.0 |
| K0S | 55.5105 | 48.9809 | 30.8882 | 20.3336 | 14.4618 | 5.7106 | 4.8575 | 34.5 |

6.3.10 Type V 160 – Standard bevel gearboxes

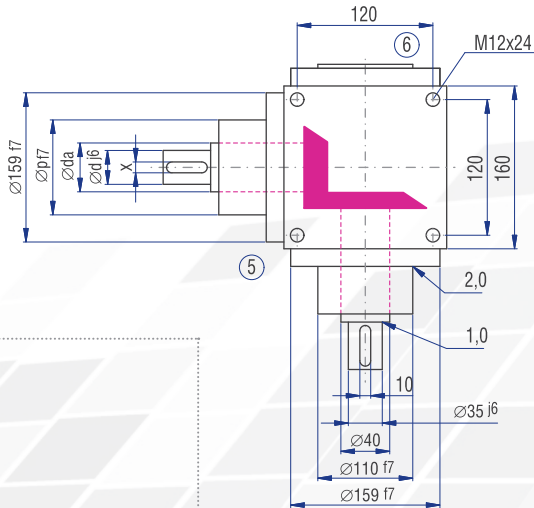
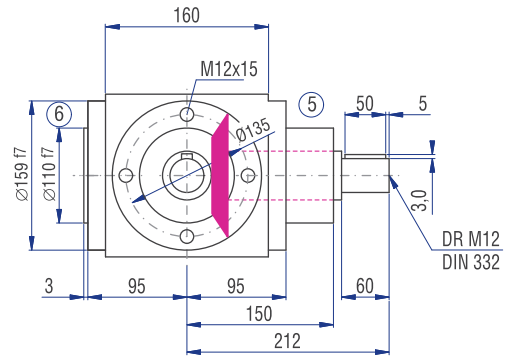
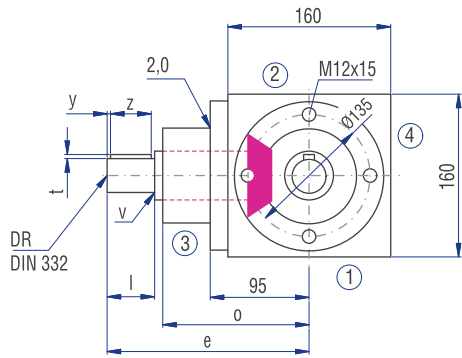
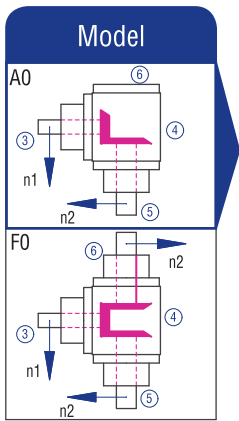

| | Gear ratio | | | | | | |
|---------|------------|-------|-----|-----|-----|-----|-----|
| | 1:1 | 1.5:1 | 2:1 | 3:1 | 4:1 | 5:1 | 6:1 |
| d [mm] | 35 | 35 | 35 | 28 | 24 | 24 | 24 |
| da [mm] | 40 | 40 | 40 | 40 | 40 | 25 | 25 |
| l [mm] | 60 | 60 | 60 | 60 | 60 | 60 | 60 |
| v [mm] | 1.5 | 1.5 | 1.5 | 1 | 1 | 0.5 | 0.5 |
| x [mm] | 10 | 10 | 10 | 8 | 8 | 8 | 8 |
| y [mm] | 5 | 5 | 5 | 5 | 5 | 5 | 5 |
| z [mm] | 50 | 50 | 50 | 50 | 50 | 50 | 50 |
| t [mm] | 3 | 3 | 3 | 3 | 3 | 3 | 3 |
| e [mm] | 212 | 212 | 212 | 212 | 232 | 232 | 232 |
| o [mm] | 150 | 150 | 150 | 150 | 170 | 170 | 170 |
| p [mm] | 110 | 110 | 110 | 100 | 100 | 100 | 100 |
| DR M | 12 | 12 | 12 | 10 | 8 | 8 | 8 |

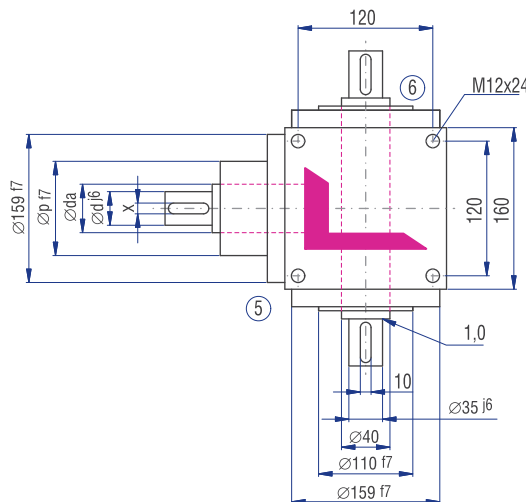
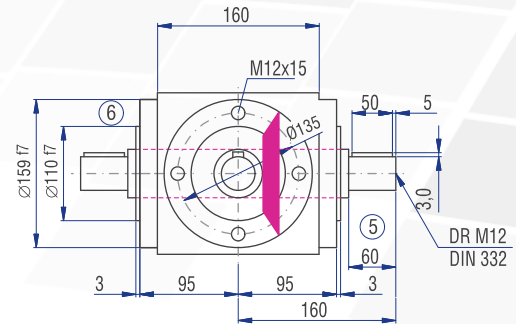
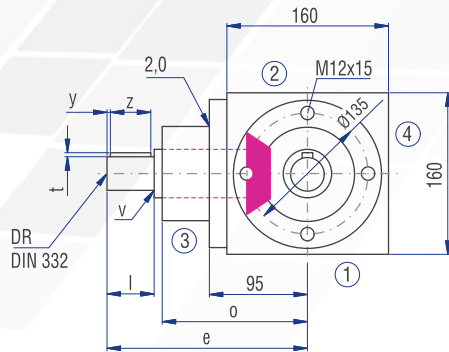
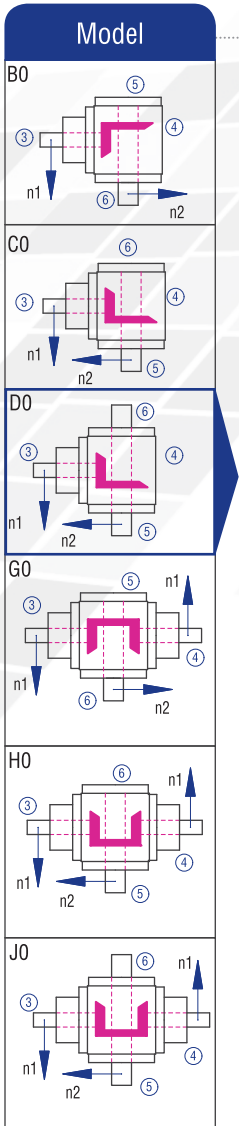

Implementation VV

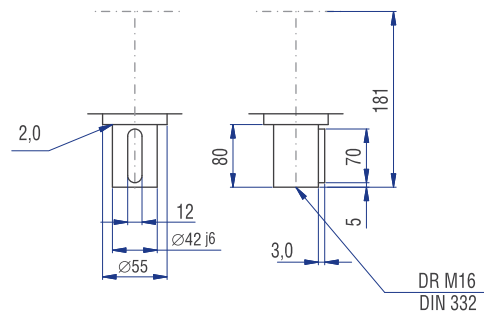

The dimensions of the Models not shown can be figured by mirroring available dimensions.

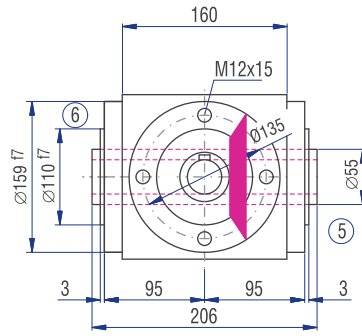
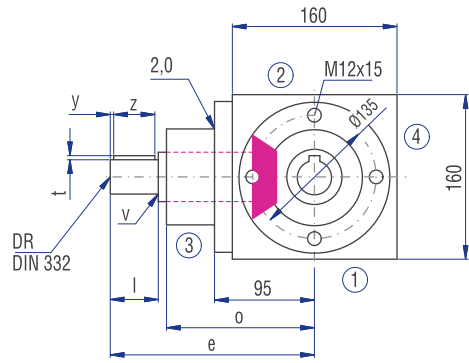

Implementation

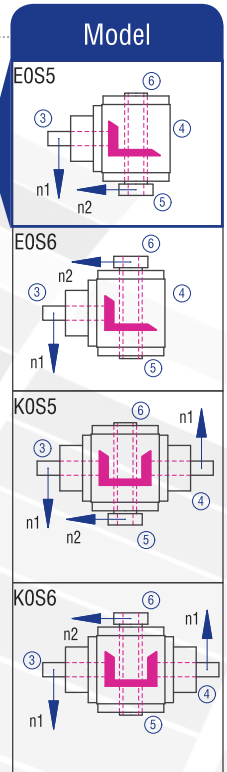
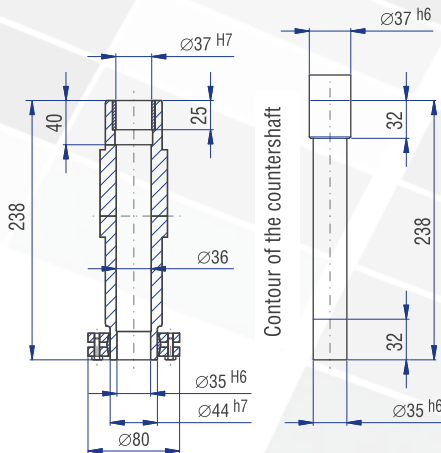
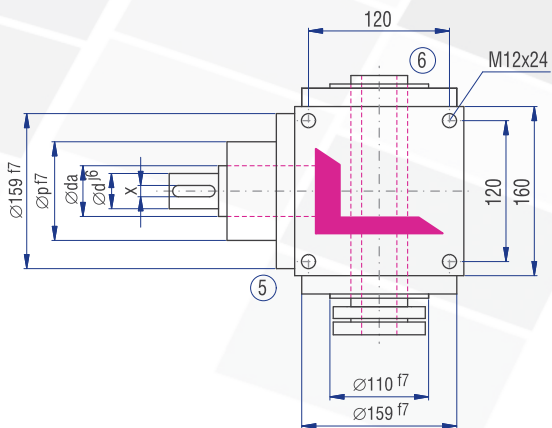
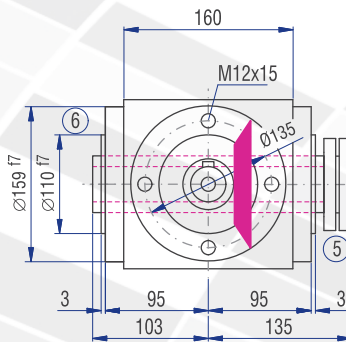
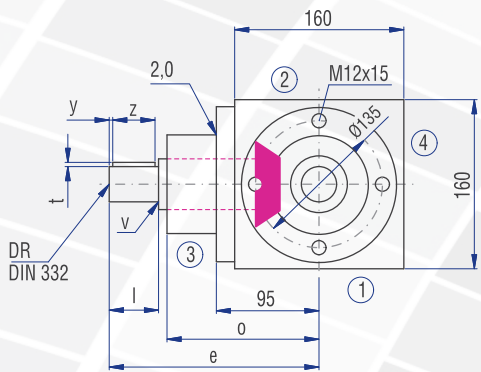
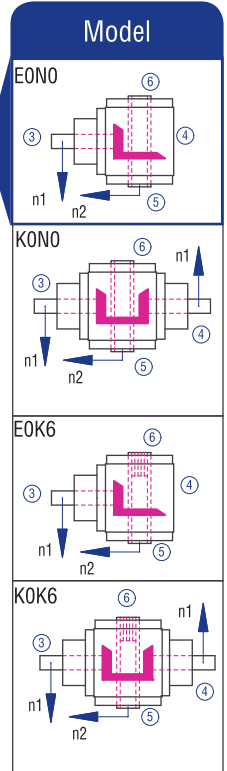
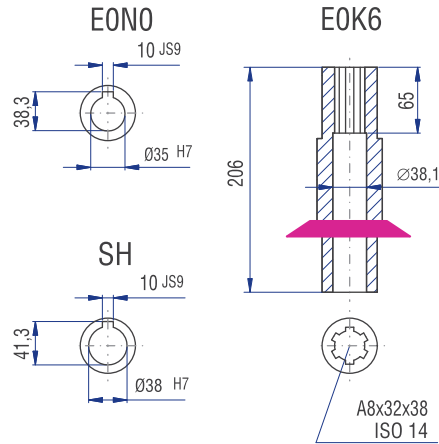
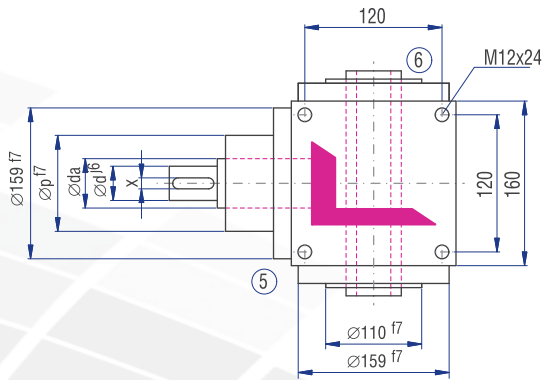

6.3.11 Type V 200 – Standard bevel gearboxes

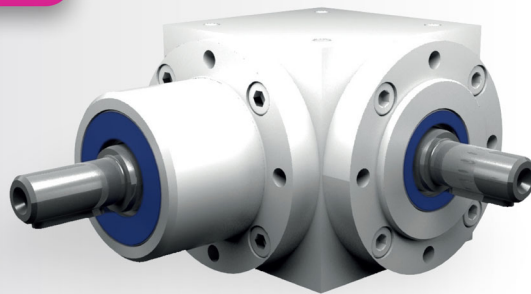

Characteristics

| Characteristic | Standard | Option |
|---------------------------------|--|--------------------|
| Toothing | Spiral toothed bevel gear set | See chapter 6.2.1 |
| Gear ratio | 1:1 to 6:1 | |
| Housing / Flanges | Grey cast iron; steel | |
| Threaded mounting hole | On all housing surfaces without flange and on all flanges. | See chapter 6.2.3 |
| Shaft | Material 1 C45, shaft ends greased Fit with ISO 6 tolerance with parallel keyway: according to DIN 6885 Sheet 1 | See chapter 4.6.2 |
| Hollow shaft | Material 1 C45, shafts greased Fit with ISO 7 tolerance with parallel keyway: according to DIN 6885 Sheet 1 | See chapter 4.6.3 |
| Radial shaft seal ring | NBR, form A | See chapter 4.8 |
| Ambient temperature | -10°C to +90°C. The values of the performance tables are valid for +20°C | See chapter 4.9.3 |
| Circumferential backlash | < 30 arcmin | See chapter 6.2.10 |
| Protection class | IP 54 | See chapter 4.5 |
| Corrosion protection | Prime coat; layer thickness > 40 µm | See chapter 4.4.1 |
| Bearing life L10h | more than 15,000h | See chapter 4.9.1 |
| Oil change intervals | Not required if the oil temperature is kept < 90°C The lifetime of the bearings can be increased by the factor 1.5 if the oil is changed after the first 500 service hours and then every 5000 service hours. | See chapter 6.2.8 |
| Lubricant | Synthetic lubricants | See chapter 6.2.8 |

Performance data

| n_1 [rpm] | 1:1 | | | 1.5:1 | | | 2:1 | | | 3:1 | | | 4:1 | | | 5:1 | | | 6:1 | | |
|-----------------|----------------|------------------|------------------|----------------|------------------|------------------|----------------|------------------|------------------|----------------|------------------|------------------|----------------|------------------|------------------|----------------|------------------|------------------|----------------|------------------|------------------|
| | n_2 [rpm] | P_{1N} [kW] | T_{2N} [Nm] | n_2 [rpm] | P_{1N} [kW] | T_{2N} [Nm] | n_2 [rpm] | P_{1N} [kW] | T_{2N} [Nm] | n_2 [rpm] | P_{1N} [kW] | T_{2N} [Nm] | n_2 [rpm] | P_{1N} [kW] | T_{2N} [Nm] | n_2 [rpm] | P_{1N} [kW] | T_{2N} [Nm] | n_2 [rpm] | P_{1N} [kW] | T_{2N} [Nm] |
| 3000 | | | | 2000 | 72.75 | 330 | 1500 | 51.25 | 310 | 1000 | 46.29 | 420 | 750 | 28.93 | 350 | 600 | 19.84 | 300 | 500 | 11.45 | 208 |
| 2400 | | | | 1600 | 63.49 | 360 | 1200 | 45.24 | 342 | 800 | 39.24 | 445 | 600 | 26.45 | 400 | 480 | 17.99 | 340 | 400 | 9.60 | 218 |
| 1500 | 1500 | 74.40 | 450 | 1000 | 48.17 | 437 | 750 | 35.13 | 425 | 500 | 28.38 | 515 | 375 | 18.81 | 455 | 300 | 12.57 | 380 | 250 | 6.54 | 237 |
| 1000 | 1000 | 56.21 | 510 | 667 | 37.13 | 505 | 500 | 27.56 | 500 | 333 | 20.37 | 555 | 250 | 13.36 | 485 | 200 | 9.26 | 420 | 167 | 4.74 | 258 |
| 750 | 750 | 45.88 | 555 | 500 | 30.31 | 550 | 375 | 22.32 | 540 | 250 | 15.98 | 580 | 188 | 10.54 | 510 | 150 | 7.27 | 440 | 125 | 3.98 | 289 |
| 500 | 500 | 34.17 | 620 | 333 | 22.57 | 615 | 250 | 16.81 | 610 | 167 | 11.04 | 600 | 125 | 7.23 | 525 | 100 | 5.18 | 470 | 83 | 2.79 | 304 |
| 250 | 250 | 19.56 | 710 | 167 | 12.70 | 690 | 125 | 9.37 | 680 | 83 | 5.76 | 630 | 63 | 3.79 | 550 | 50 | 2.78 | 505 | 42 | 1.44 | 311 |
| 50 | 50 | 4.13 | 750 | 33 | 2.73 | 750 | 25 | 2.07 | 750 | 17 | 1.29 | 690 | 13 | 0.80 | 580 | 10 | 0.58 | 525 | 8 | 0.28 | 306 |
| P_{1Nt} [kW] | 26.0 | | | 26.0 | | | 26.0 | | | 26.0 | | | 26.0 | | | 26.0 | | | 26.0 | | |
| T_{2max} [Nm] | 1090 | | | 980 | | | 980 | | | 910 | | | 860 | | | 860 | | | 625 | | |

Permissible radial force F_{r1} and axial force F_{a1} on shaft N_1

| n_1 [rpm] | 3000 | | 1000 | | 500 | | 250 | | 100 | | 50 | |
|-------------|-----------|-----------|-----------|-----------|-----------|-----------|-----------|-----------|-----------|-----------|-----------|-----------|
| T_2 [Nm] | F_r [N] | F_a [N] | F_r [N] | F_a [N] | F_r [N] | F_a [N] | F_r [N] | F_a [N] | F_r [N] | F_a [N] | F_r [N] | F_a [N] |
| < 500 | 2200 | 1100 | 1700 | 850 | 3200 | 1600 | 3900 | 1950 | 5000 | 2500 | 6200 | 3100 |
| > 500 | 1840 | 920 | 1420 | 710 | 2670 | 1335 | 3250 | 1625 | 4170 | 2085 | 5170 | 2585 |

Permissible radial force F_{r2} and axial force F_{a2} on shaft N_2

| n_2 [rpm] | 3000 | | 1000 | | 500 | | 250 | | 100 | | 50 | |
|-------------|-----------|-----------|-----------|-----------|-----------|-----------|-----------|-----------|-----------|-----------|-----------|-----------|
| T_2 [Nm] | F_r [N] | F_a [N] | F_r [N] | F_a [N] | F_r [N] | F_a [N] | F_r [N] | F_a [N] | F_r [N] | F_a [N] | F_r [N] | F_a [N] |
| < 500 | 3200 | 1600 | 4300 | 2150 | 5000 | 2500 | 6500 | 3250 | 8000 | 4000 | 10000 | 5000 |
| > 500 | 2670 | 1335 | 3580 | 1790 | 4170 | 2085 | 5420 | 2710 | 6670 | 3335 | 8330 | 4165 |

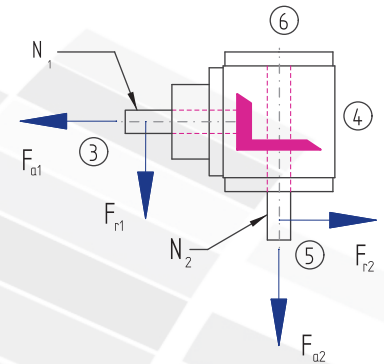

Inertia moments/mass

Inertia moment J_1 related to the fast-rotating shaft (N_1)

| Model | Inertia moment [kgcm ²] | | | | | | | Mass [kg] |
|-------|-------------------------------------|----------|----------|---------|---------|---------|---------|-----------|
| | 1:1 | 1.5:1 | 2:1 | 3:1 | 4:1 | 5:1 | 6:1 | |
| A0 | 121.2522 | 57.6950 | 36.3095 | 18.8322 | 14.2651 | 6.1470 | 5.3881 | 52.0 |
| B0 | 174.7000 | 103.5829 | 71.6215 | 34.1931 | 22.7181 | 12.8770 | 10.0616 | 48.0 |
| C0 | 174.7000 | 103.5829 | 71.6215 | 34.1931 | 22.7181 | 12.8770 | 10.0616 | 48.0 |
| D0 | 177.8173 | 104.9684 | 72.4008 | 34.5395 | 22.9130 | 13.0016 | 10.1482 | 50.0 |
| E0N | 201.3904 | 109.0276 | 76.4341 | 35.2209 | 23.3588 | 13.8070 | 10.7075 | 48.0 |
| E0S | 222.4124 | 118.3707 | 81.6896 | 37.5567 | 24.6726 | 14.6479 | 11.2914 | 49.3 |
| F0 | 181.8783 | 84.6400 | 51.4661 | 25.5685 | 18.0543 | 8.5721 | 7.0721 | 60.0 |
| G0 | 235.3261 | 134.3330 | 92.7745 | 46.2891 | 33.1941 | 16.5990 | 13.7656 | 58.0 |
| H0 | 235.3261 | 134.3330 | 92.7745 | 46.2891 | 33.1941 | 16.5990 | 13.7656 | 58.0 |
| J0 | 238.4434 | 135.7185 | 93.5538 | 46.6355 | 33.3890 | 16.7236 | 13.8522 | 60.0 |
| K0N | 262.0165 | 139.7777 | 97.5871 | 47.3169 | 33.8348 | 17.5290 | 14.4115 | 58.0 |
| K0S | 283.0385 | 149.1208 | 102.8426 | 49.6527 | 35.1486 | 18.3699 | 14.9954 | 59.3 |

6.3.11 Type V 200 – Standard bevel gearboxes

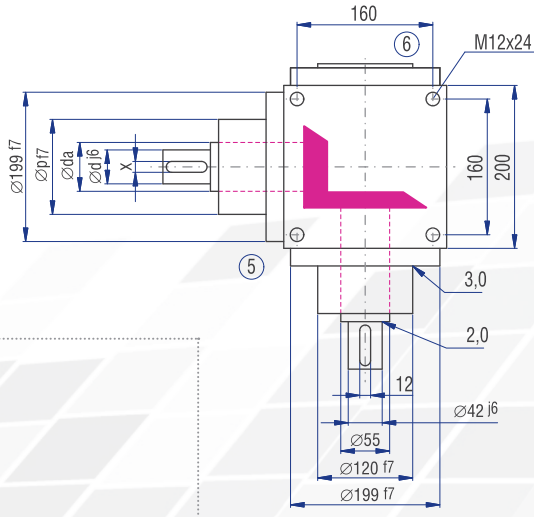
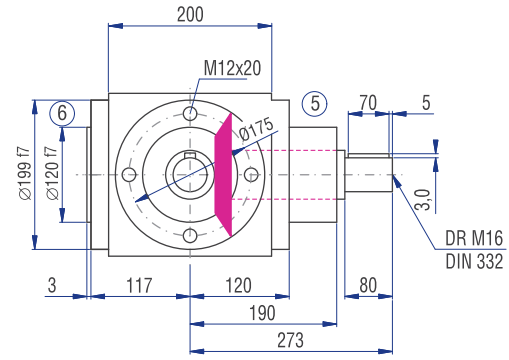
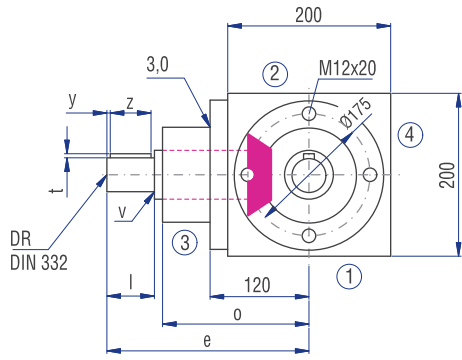
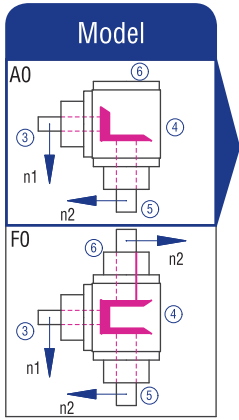

| | Gear ratio | | | | | | |
|---------|------------|-------|-----|-----|-----|-----|-----|
| | 1:1 | 1.5:1 | 2:1 | 3:1 | 4:1 | 5:1 | 6:1 |
| d [mm] | 42 | 42 | 42 | 35 | 35 | 28 | 28 |
| da [mm] | 55 | 55 | 55 | 40 | 40 | 30 | 30 |
| l [mm] | 80 | 80 | 80 | 68 | 68 | 68 | 68 |
| v [mm] | 2 | 2 | 2 | 1 | 1 | 0 | 0 |
| x [mm] | 12 | 12 | 12 | 10 | 10 | 8 | 8 |
| y [mm] | 5 | 5 | 5 | 3 | 3 | 3 | 3 |
| z [mm] | 70 | 70 | 70 | 63 | 63 | 63 | 63 |
| t [mm] | 3 | 3 | 3 | 3 | 3 | 3 | 3 |
| e [mm] | 273 | 273 | 273 | 261 | 261 | 261 | 261 |
| o [mm] | 190 | 190 | 190 | 190 | 190 | 190 | 190 |
| p [mm] | 120 | 120 | 120 | 120 | 120 | 110 | 110 |
| DR M | 16 | 16 | 16 | 12 | 12 | 10 | 10 |

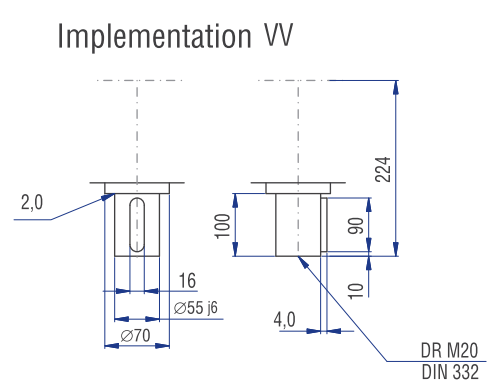
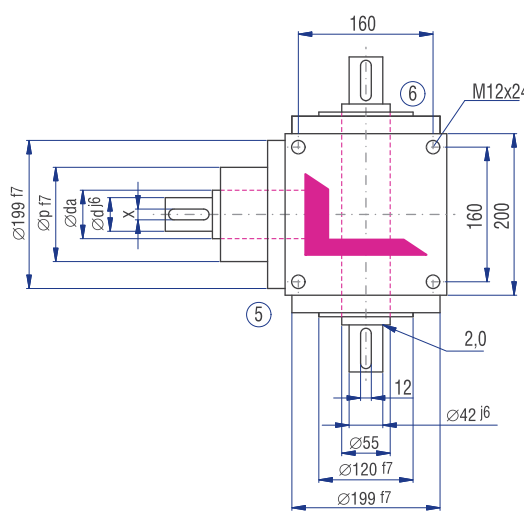
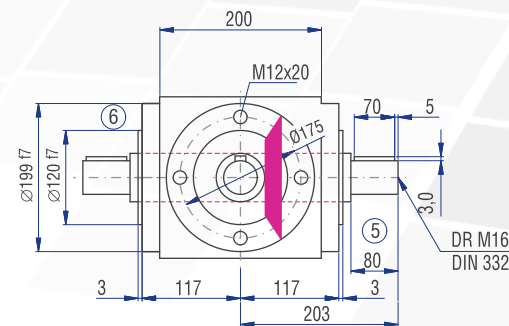
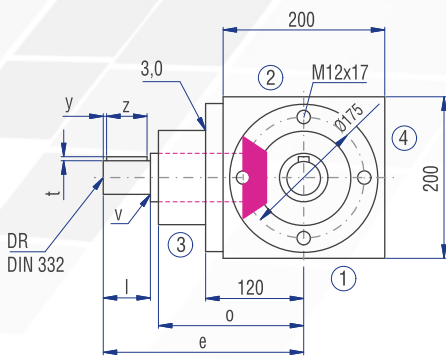
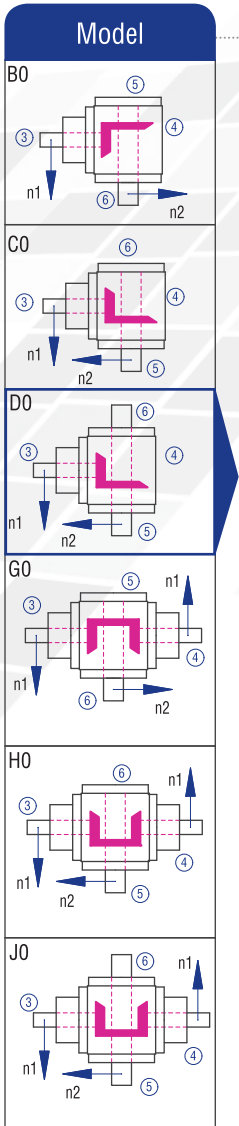

Implementation WV

The dimensions of the Models not shown can be figured by mirroring available dimensions.

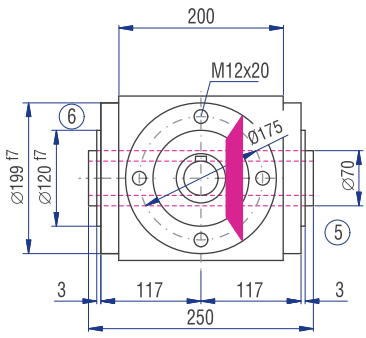
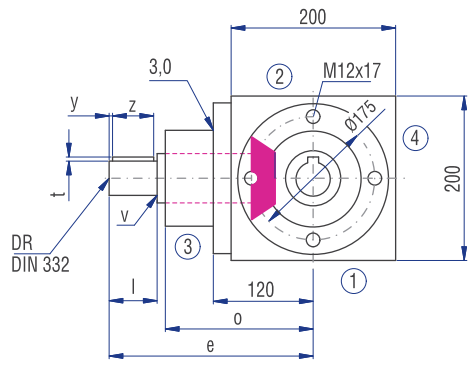

Implementation

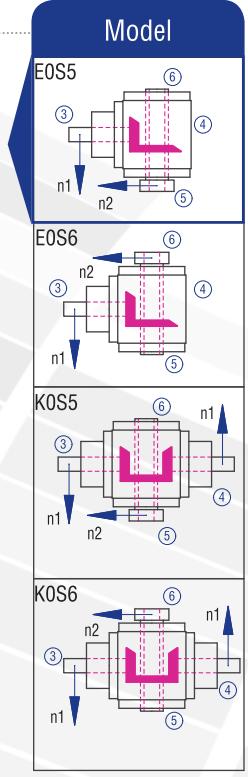
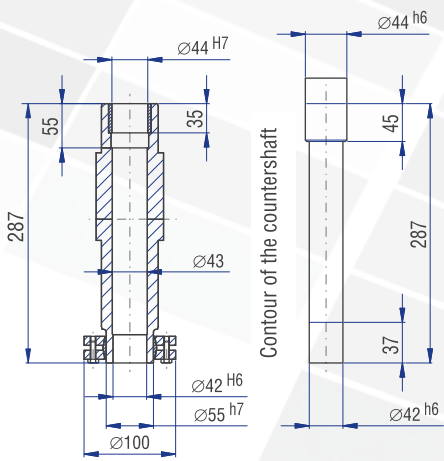
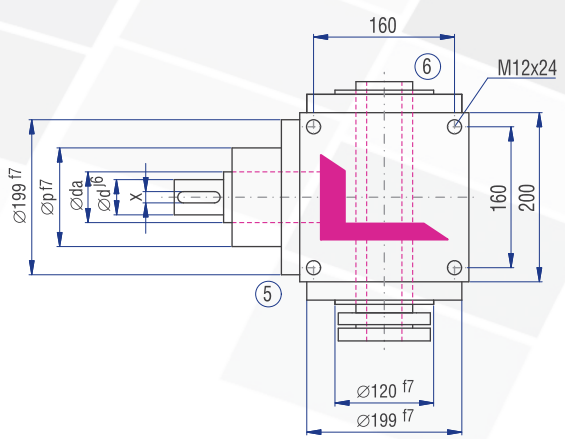
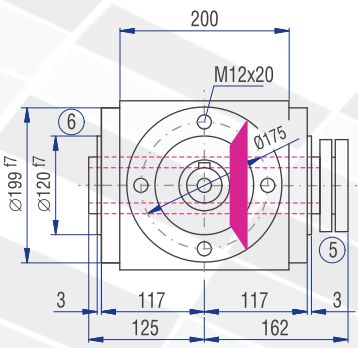
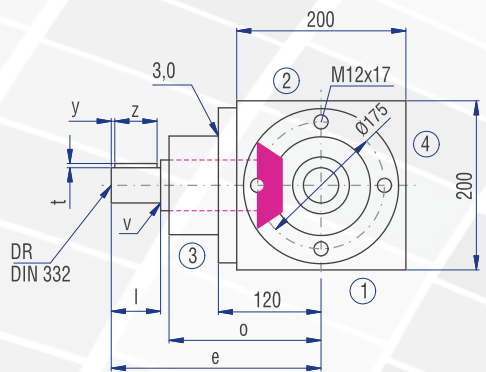
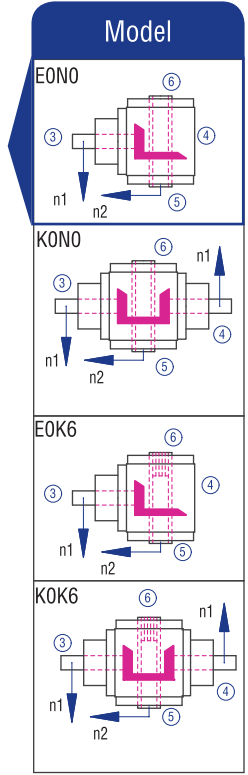
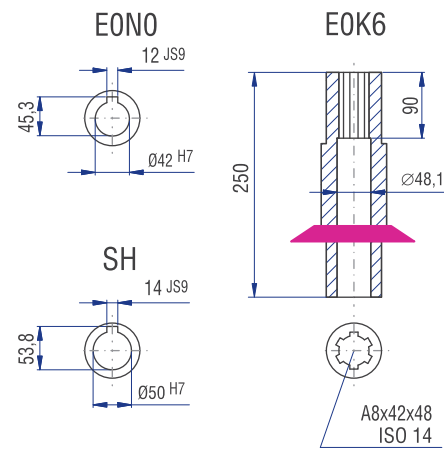
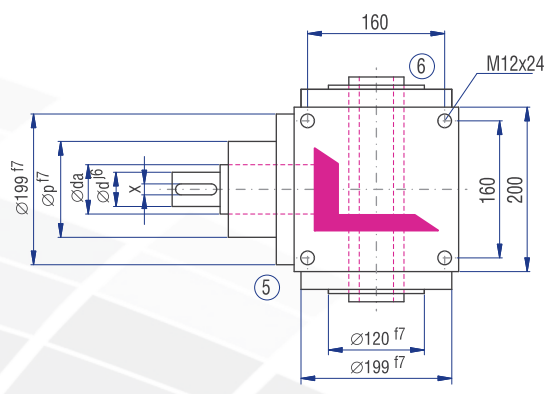

6.3.12 Type V 230 – Standard bevel gearboxes

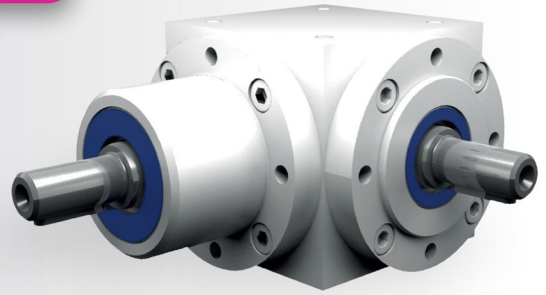

Characteristics

| Characteristic | Standard | Option |
|---------------------------------|--|--------------------|
| Toothing | Spiral toothed bevel gear set | See chapter 6.2.1 |
| Gear ratio | 1:1 to 6:1 | |
| Housing / Flanges | Grey cast iron; steel | |
| Threaded mounting hole | On all housing surfaces without flange and on all flanges. | See chapter 6.2.3 |
| Shaft | Material 1 C45, shaft ends greased Fit with ISO 6 tolerance with parallel keyway: according to DIN 6885 Sheet 1 | See chapter 4.6.2 |
| Hollow shaft | Material 1 C45, shafts greased Fit with ISO 7 tolerance with parallel keyway: according to DIN 6885 Sheet 1 | See chapter 4.6.3 |
| Radial shaft seal ring | NBR, form A | See chapter 4.8 |
| Ambient temperature | -10°C to +90°C. The values of the performance tables are valid for +20°C | See chapter 4.9.3 |
| Circumferential backlash | < 30 arcmin | See chapter 6.2.10 |
| Protection class | IP 54 | See chapter 4.5 |
| Corrosion protection | Prime coat; layer thickness > 40 µm | See chapter 4.4.1 |
| Bearing life L10h | more than 15,000h | See chapter 4.9.1 |
| Oil change intervals | Not required if the oil temperature is kept < 90°C The lifetime of the bearings can be increased by the factor 1.5 if the oil is changed after the first 500 service hours and then every 5000 service hours. | See chapter 6.2.8 |
| Lubricant | Synthetic lubricants | See chapter 6.2.8 |

Performance data

| n ₁ [rpm] | 1:1 | | 1.5:1 | | | 2:1 | | | 3:1 | | | 4:1 | | | 5:1 | | | 6:1 | | | | | | |
|-------------------------|-------------------------|-------------------------|-------------------------|-------------------------|-------------------------|-------------------------|-------------------------|-------------------------|-------------------------|-------------------------|-------------------------|-------------------------|-------------------------|-------------------------|-------------------------|-------------------------|-------------------------|-------------------------|-------------------------|-------------------------|-------------------------|--|--|--|
| | n ₂ [rpm] | P _{1N} [kW] | T _{2N} [Nm] | n ₂ [rpm] | P _{1N} [kW] | T _{2N} [Nm] | n ₂ [rpm] | P _{1N} [kW] | T _{2N} [Nm] | n ₂ [rpm] | P _{1N} [kW] | T _{2N} [Nm] | n ₂ [rpm] | P _{1N} [kW] | T _{2N} [Nm] | n ₂ [rpm] | P _{1N} [kW] | T _{2N} [Nm] | n ₂ [rpm] | P _{1N} [kW] | T _{2N} [Nm] | | | |
| 3000 | | | | 2000 | 99.20 | 450 | 1500 | 87.63 | 530 | 1000 | 44.09 | 400 | 750 | 36.37 | 440 | 600 | 33.73 | 510 | 500 | 20.17 | 366 | | | |
| 2400 | | | | 1600 | 91.35 | 518 | 1200 | 80.02 | 605 | 800 | 39.68 | 450 | 600 | 32.74 | 495 | 480 | 29.10 | 550 | 400 | 18.08 | 410 | | | |
| 1500 | 1500 | 87.63 | 530 | 1000 | 72.20 | 655 | 750 | 59.11 | 715 | 500 | 29.76 | 540 | 375 | 24.80 | 600 | 300 | 21.00 | 635 | 250 | 13.50 | 490 | | | |
| 1000 | 1000 | 71.65 | 650 | 667 | 56.21 | 765 | 500 | 45.19 | 820 | 333 | 23.33 | 635 | 250 | 18.60 | 675 | 200 | 15.76 | 715 | 167 | 9.92 | 540 | | | |
| 750 | 750 | 60.76 | 735 | 500 | 45.47 | 825 | 375 | 36.79 | 890 | 250 | 19.29 | 700 | 188 | 15.19 | 735 | 150 | 12.73 | 770 | 125 | 7.78 | 565 | | | |
| 500 | 500 | 45.19 | 820 | 333 | 33.79 | 920 | 250 | 26.73 | 970 | 167 | 14.07 | 765 | 125 | 10.95 | 795 | 100 | 9.15 | 830 | 83 | 5.42 | 590 | | | |
| 250 | 250 | 26.73 | 970 | 167 | 20.57 | 1,120 | 125 | 16.88 | 1,225 | 83 | 7.58 | 825 | 63 | 5.99 | 870 | 50 | 5.07 | 920 | 42 | 2.82 | 610 | | | |
| 50 | 50 | 7.00 | 1,270 | 33 | 4.89 | 1,330 | 25 | 3.66 | 1,330 | 17 | 1.63 | 870 | 13 | 1.35 | 980 | 10 | 1.09 | 990 | 8 | 0.57 | 625 | | | |
| P _{1Nt} [kW] | 34.0 | | | 34.0 | | | 34.0 | | | 34.0 | | | 34.0 | | | 34.0 | | | 34.0 | | | | | |
| T _{2max} [Nm] | 1500 | | | 1400 | | | 1400 | | | 1300 | | | 1300 | | | 1200 | | | 1000 | | | | | |

Permissible radial force F_{r1} and axial force Fa₁ on shaft N₁

| n ₁ [rpm] | 3000 | | 1000 | | 500 | | 250 | | 100 | | 50 | |
|----------------------|--------------------|--------------------|--------------------|--------------------|--------------------|--------------------|--------------------|--------------------|--------------------|--------------------|--------------------|--------------------|
| T ₂ [Nm] | F _r [N] | F _a [N] | F _r [N] | F _a [N] | F _r [N] | F _a [N] | F _r [N] | F _a [N] | F _r [N] | F _a [N] | F _r [N] | F _a [N] |
| < 750 | 4600 | 2300 | 5150 | 2575 | 7200 | 3600 | 9450 | 4725 | 11250 | 5625 | 13100 | 6550 |
| > 750 | 3832 | 1916 | 4290 | 2145 | 6000 | 3000 | 7876 | 3938 | 9376 | 4688 | 10918 | 5459 |

Permissible radial force F_{r2} and axial force Fa₂ on shaft N₂

| n ₂ [rpm] | 3000 | | 1000 | | 500 | | 250 | | 100 | | 50 | |
|----------------------|--------------------|--------------------|--------------------|--------------------|--------------------|--------------------|--------------------|--------------------|--------------------|--------------------|--------------------|--------------------|
| T ₂ [Nm] | F _r [N] | F _a [N] | F _r [N] | F _a [N] | F _r [N] | F _a [N] | F _r [N] | F _a [N] | F _r [N] | F _a [N] | F _r [N] | F _a [N] |
| < 750 | 5850 | 2925 | 8650 | 4325 | 10500 | 5250 | 12250 | 6125 | 15000 | 7500 | 19000 | 9500 |
| > 750 | 4876 | 2438 | 7208 | 3604 | 8750 | 4375 | 10208 | 5104 | 12500 | 6250 | 15830 | 7915 |

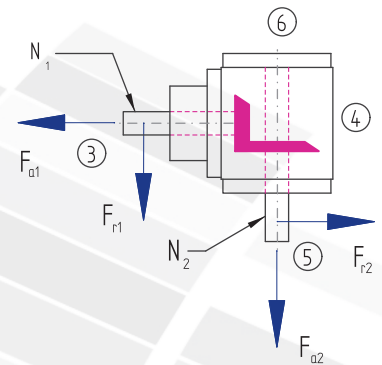

Inertia moments/mass

Inertia moment J₁ related to the fast-rotating shaft (N₁)

| Model | Inertia moment [kgcm ²] | | | | | | | Mass [kg] |
|-------|-------------------------------------|----------|----------|----------|---------|---------|---------|-----------|
| | 1:1 | 1.5:1 | 2:1 | 3:1 | 4:1 | 5:1 | 6:1 | |
| A0 | 506.0000 | 215.0000 | 132.0000 | 55.0000 | 48.0000 | 42.0000 | 37.0000 | 79.0 |
| B0 | 502.0000 | 220.0000 | 136.0000 | 57.0000 | 49.0000 | 42.0000 | 38.0000 | 76.0 |
| C0 | 502.0000 | 220.0000 | 136.0000 | 57.0000 | 49.0000 | 42.0000 | 38.0000 | 76.0 |
| D0 | 512.0000 | 224.0000 | 138.0000 | 58.0000 | 49.0000 | 43.0000 | 38.0000 | 78.0 |
| E0N | 512.0000 | 229.0000 | 142.0000 | 60.0000 | 50.0000 | 43.0000 | 38.0000 | 71.0 |
| E0S | 573.0000 | 256.0000 | 157.0000 | 67.0000 | 54.0000 | 46.0000 | 40.0000 | 72.0 |
| F0 | 759.0000 | 332.0000 | 201.0000 | 77.0000 | 63.0000 | 53.0000 | 45.0000 | 97.0 |
| G0 | 755.0000 | 318.0000 | 200.0000 | 91.0000 | 82.0000 | 72.0000 | 68.0000 | 100.0 |
| H0 | 755.0000 | 318.0000 | 200.0000 | 91.0000 | 82.0000 | 72.0000 | 68.0000 | 100.0 |
| J0 | 765.0000 | 322.0000 | 202.0000 | 92.0000 | 82.0000 | 73.0000 | 68.0000 | 102.0 |
| K0N | 765.0000 | 327.0000 | 206.0000 | 94.0000 | 83.0000 | 73.0000 | 68.0000 | 95.0 |
| K0S | 826.0000 | 354.0000 | 221.0000 | 101.0000 | 87.0000 | 76.0000 | 70.0000 | 96.0 |

6.3.12 Type V 230 – Standard bevel gearboxes

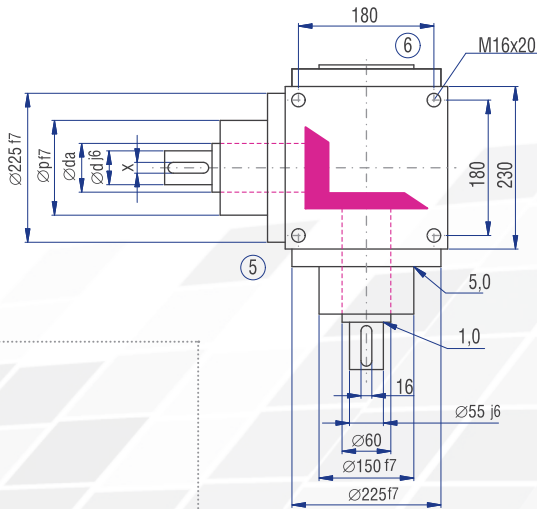
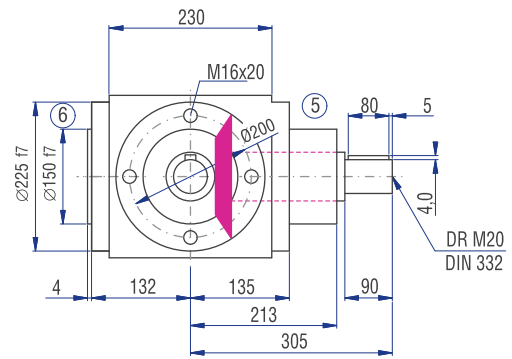
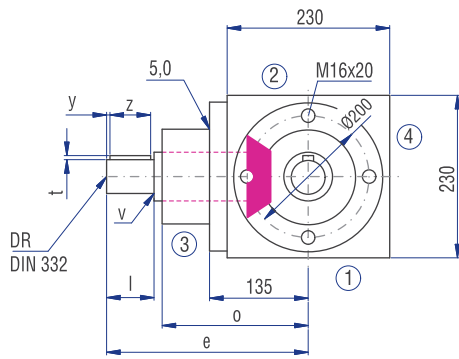
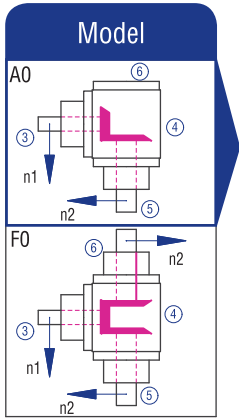

| | Gear ratio | | | | | | |
|---------|------------|-------|-----|-----|-----|-----|-----|
| | 1:1 | 1.5:1 | 2:1 | 3:1 | 4:1 | 5:1 | 6:1 |
| d [mm] | 55 | 55 | 55 | 40 | 40 | 35 | 35 |
| da [mm] | 60 | 60 | 60 | 50 | 50 | 45 | 45 |
| l [mm] | 90 | 90 | 90 | 80 | 80 | 70 | 70 |
| v [mm] | 1 | 1 | 1 | 1 | 1 | 1 | 1 |
| x [mm] | 16 | 16 | 16 | 12 | 12 | 10 | 10 |
| y [mm] | 5 | 5 | 5 | 5 | 5 | 3 | 3 |
| z [mm] | 80 | 80 | 80 | 70 | 70 | 63 | 63 |
| t [mm] | 2.5 | 2.5 | 2.5 | 3 | 3 | 3 | 3 |
| e [mm] | 305 | 305 | 305 | 310 | 310 | 300 | 300 |
| o [mm] | 213 | 213 | 213 | 228 | 228 | 228 | 228 |
| p [mm] | 150 | 150 | 150 | 140 | 140 | 140 | 140 |
| DR M | 20 | 20 | 20 | 16 | 16 | 16 | 16 |

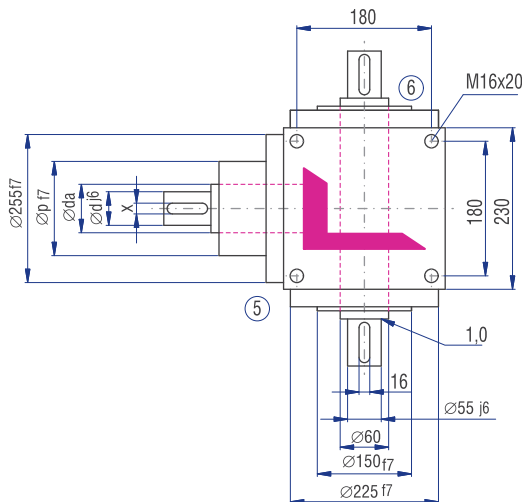
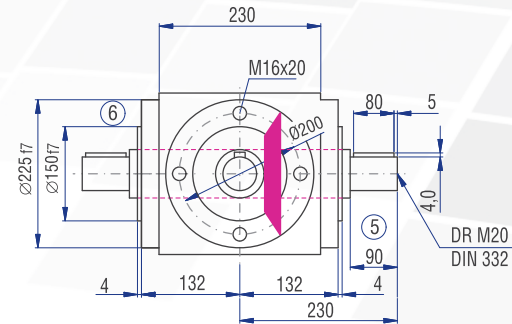
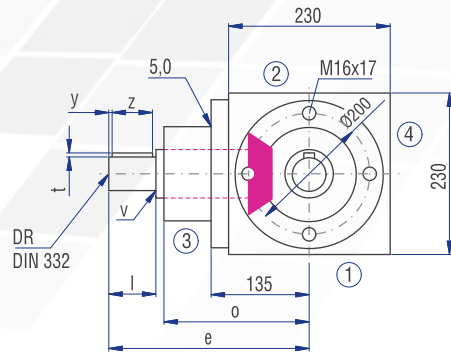
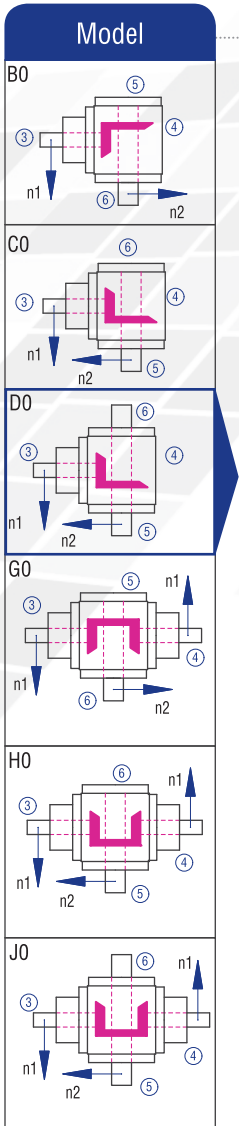

Implementation W

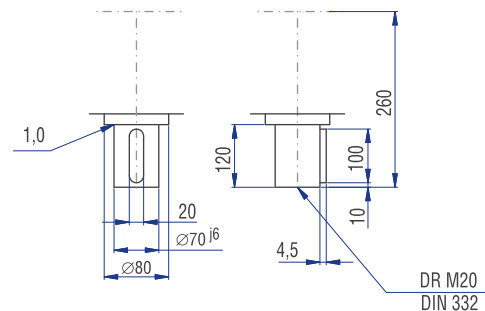

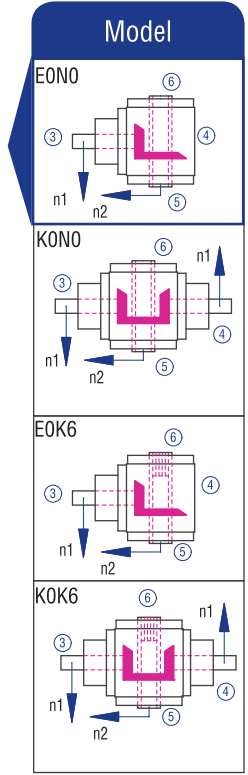
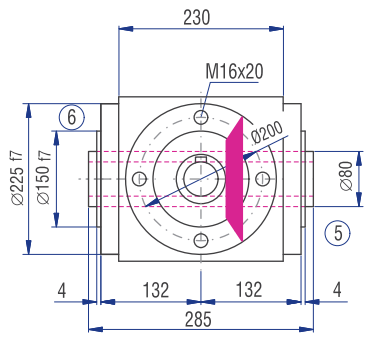
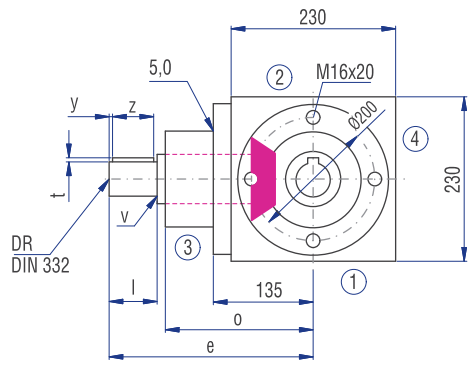

Implementation

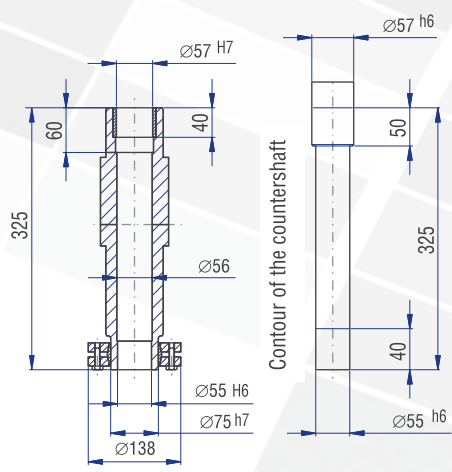
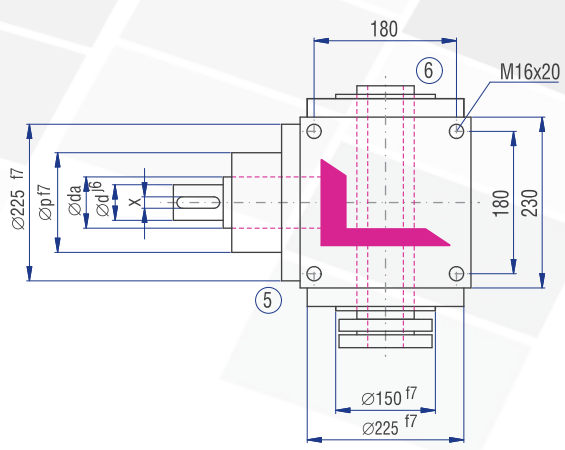
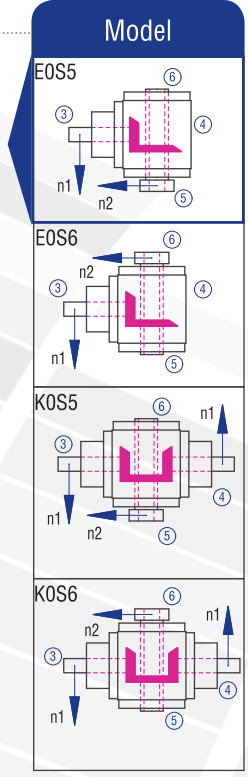
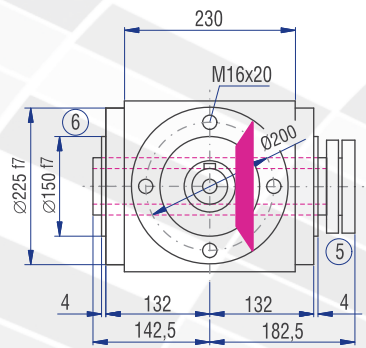
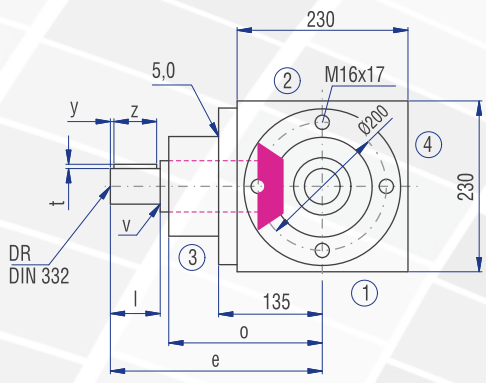
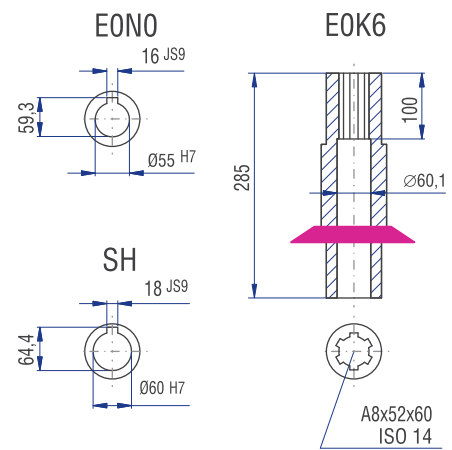
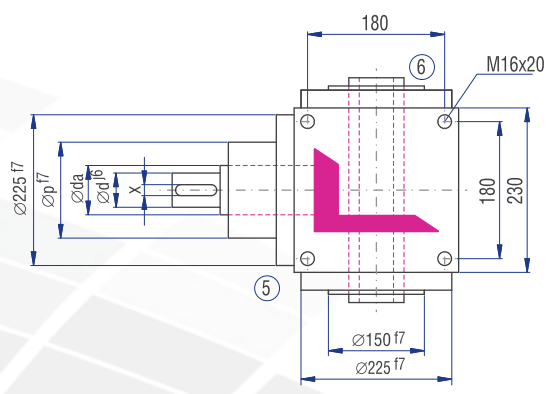

6.3.13 Type V 260 – Standard bevel gearboxes

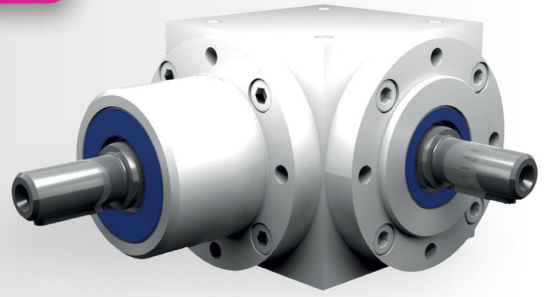

Characteristics

| Characteristic | Standard | Option |
|---------------------------------|--|--------------------|
| Toothing | Spiral toothed bevel gear set | See chapter 6.2.1 |
| Gear ratio | 1:1 to 6:1 | |
| Housing / Flanges | Grey cast iron; steel | |
| Threaded mounting hole | On all housing surfaces without flange and on all flanges. | See chapter 6.2.3 |
| Shaft | Material 1 C45, shaft ends greased Fit with ISO 6 tolerance with parallel keyway: according to DIN 6885 Sheet 1 | See chapter 4.6.2 |
| Hollow shaft | Material 1 C45, shafts greased Fit with ISO 7 tolerance with parallel keyway: according to DIN 6885 Sheet 1 | See chapter 4.6.3 |
| Radial shaft seal ring | NBR, form A | See chapter 4.8 |
| Ambient temperature | -10°C to +90°C. The values of the performance tables are valid for +20°C | See chapter 4.9.3 |
| Circumferential backlash | < 30 arcmin | See chapter 6.2.10 |
| Protection class | IP 54 | See chapter 4.5 |
| Corrosion protection | Prime coat; layer thickness > 40 µm | See chapter 4.4.1 |
| Bearing life L10h | more than 15,000h | See chapter 4.9.1 |
| Oil change intervals | Not required if the oil temperature is kept < 90°C The lifetime of the bearings can be increased by the factor 1.5 if the oil is changed after the first 500 service hours and then every 5000 service hours. | See chapter 6.2.8 |
| Lubricant | Synthetic lubricants | See chapter 6.2.8 |

Performance data

| n ₁ [rpm] | 1:1 | | | 1.5:1 | | | 2:1 | | | 3:1 | | | 4:1 | | | 5:1 | | | 6:1 | | | | | |
|-------------------------|-------------------------|-------------------------|-------------------------|-------------------------|-------------------------|-------------------------|-------------------------|-------------------------|-------------------------|-------------------------|-------------------------|-------------------------|-------------------------|-------------------------|-------------------------|-------------------------|-------------------------|-------------------------|-------------------------|-------------------------|-------------------------|--|--|--|
| | n ₂ [rpm] | P _{1N} [kW] | T _{2N} [Nm] | n ₂ [rpm] | P _{1N} [kW] | T _{2N} [Nm] | n ₂ [rpm] | P _{1N} [kW] | T _{2N} [Nm] | n ₂ [rpm] | P _{1N} [kW] | T _{2N} [Nm] | n ₂ [rpm] | P _{1N} [kW] | T _{2N} [Nm] | n ₂ [rpm] | P _{1N} [kW] | T _{2N} [Nm] | n ₂ [rpm] | P _{1N} [kW] | T _{2N} [Nm] | | | |
| 3000 | | | | 2000 | 189.58 | 860 | 1500 | 133.92 | 810 | 1000 | 85.97 | 780 | 750 | 57.87 | 700 | 600 | 46.29 | 700 | 500 | 27.27 | 495 | | | |
| 2400 | | | | 1600 | 158.72 | 900 | 1200 | 112.43 | 850 | 800 | 72.39 | 821 | 600 | 51.58 | 780 | 480 | 40.21 | 760 | 400 | 23.12 | 524 | | | |
| 1500 | 1500 | 157.07 | 950 | 1000 | 104.71 | 950 | 750 | 78.53 | 950 | 500 | 49.60 | 900 | 375 | 37.20 | 900 | 300 | 29.10 | 880 | 250 | 16.36 | 594 | | | |
| 1000 | 1000 | 115.73 | 1,050 | 667 | 77.19 | 1,050 | 500 | 57.87 | 1,050 | 333 | 36.34 | 990 | 250 | 28.93 | 1,050 | 200 | 21.82 | 990 | 167 | 12.93 | 702 | | | |
| 750 | 750 | 96.72 | 1,170 | 500 | 64.48 | 1,170 | 375 | 48.36 | 1,170 | 250 | 28.93 | 1,050 | 188 | 22.73 | 1,100 | 150 | 18.19 | 1,100 | 125 | 10.91 | 792 | | | |
| 500 | 500 | 72.75 | 1,320 | 333 | 47.72 | 1,300 | 250 | 35.27 | 1,280 | 167 | 20.43 | 1,110 | 125 | 16.26 | 1,180 | 100 | 13.23 | 1,200 | 83 | 8.06 | 878 | | | |
| 250 | 250 | 42.44 | 1,540 | 167 | 27.43 | 1,490 | 125 | 20.12 | 1,460 | 83 | 11.16 | 1,220 | 63 | 8.61 | 1,250 | 50 | 7.11 | 1,290 | 42 | 4.35 | 940 | | | |
| 50 | 50 | 9.64 | 1,750 | 33 | 6.18 | 1,700 | 25 | 4.55 | 1,650 | 17 | 2.55 | 1,360 | 13 | 1.82 | 1,320 | 10 | 1.47 | 1,330 | 8 | 0.87 | 951 | | | |
| P _{1Nt} [kW] | 42.0 | | | 42.0 | | | 42.0 | | | 42.0 | | | 42.0 | | | 42.0 | | | 42.0 | | | | | |
| T _{2max} [Nm] | 2310 | | | 2100 | | | 2100 | | | 1940 | | | 1940 | | | 1910 | | | 1730 | | | | | |

Permissible radial force F_{r1} and axial force Fa₁ on shaft N₁

| n ₁ [rpm] | 3000 | | 1000 | | 500 | | 250 | | 100 | | 50 | |
|----------------------|--------------------|--------------------|--------------------|--------------------|--------------------|--------------------|--------------------|--------------------|--------------------|--------------------|--------------------|--------------------|
| T ₂ [Nm] | F _r [N] | F _a [N] | F _r [N] | F _a [N] | F _r [N] | F _a [N] | F _r [N] | F _a [N] | F _r [N] | F _a [N] | F _r [N] | F _a [N] |
| < 950 | 7000 | 3500 | 8600 | 4300 | 11200 | 5600 | 15000 | 7500 | 17500 | 8750 | 20000 | 10000 |
| > 950 | 5830 | 2915 | 7170 | 3585 | 9330 | 4665 | 12500 | 6250 | 14580 | 7290 | 16670 | 8335 |

Permissible radial force F_{r2} and axial force Fa₂ on shaft N₂

| n ₂ [rpm] | 3000 | | 1000 | | 500 | | 250 | | 100 | | 50 | |
|----------------------|--------------------|--------------------|--------------------|--------------------|--------------------|--------------------|--------------------|--------------------|--------------------|--------------------|--------------------|--------------------|
| T ₂ [Nm] | F _r [N] | F _a [N] | F _r [N] | F _a [N] | F _r [N] | F _a [N] | F _r [N] | F _a [N] | F _r [N] | F _a [N] | F _r [N] | F _a [N] |
| < 950 | 8500 | 4250 | 13000 | 6500 | 16000 | 8000 | 18000 | 9000 | 22000 | 11000 | 28000 | 14000 |
| > 950 | 7080 | 3540 | 10830 | 5415 | 13330 | 6665 | 15000 | 7500 | 18330 | 9165 | 23330 | 11665 |

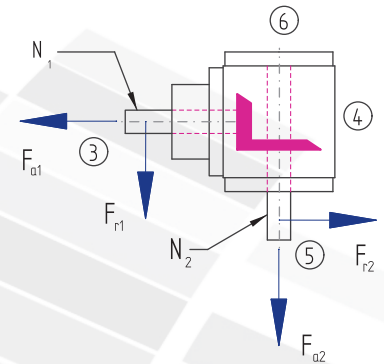

Inertia moments/mass

Inertia moment J₁ related to the fast-rotating shaft (N₁)

| Model | Inertia moment [kgcm ²] | | | | | | | Mass [kg] |
|-------|-------------------------------------|---------|---------|---------|---------|---------|---------|-----------|
| | 1:1 | 1.5:1 | 2:1 | 3:1 | 4:1 | 5:1 | 6:1 | |
| A0 | 814.200 | 305.933 | 194.275 | 85.0833 | 46.7738 | 37.2840 | 31.8083 | 85.0 |
| B0 | 827.440 | 168.262 | 281.335 | 117.221 | 66.6638 | 50.0136 | 40.7039 | 85.0 |
| C0 | 827.440 | 168.262 | 281.335 | 117.221 | 66.6638 | 50.0136 | 40.7039 | 85.0 |
| D0 | 841.850 | 383.556 | 284.938 | 52.2667 | 67.5644 | 50.5900 | 41.1042 | 88.0 |
| E0N | 828.690 | 413.262 | 287.898 | 120.110 | 68.2888 | 51.0536 | 41.4261 | 82.0 |
| E0S | 892.340 | 441.551 | 303.810 | 127.180 | 72.2656 | 53.5988 | 43.1936 | 84.9 |
| F0 | 1221.300 | 486.867 | 296.050 | 130.317 | 72.2175 | 53.5680 | 43.1167 | 105.0 |
| G0 | 1234.540 | 293.262 | 373.835 | 157.071 | 87.9938 | 71.0136 | 61.2039 | 109.0 |
| H0 | 1234.540 | 293.262 | 373.835 | 157.071 | 87.9938 | 71.0136 | 61.2039 | 109.0 |
| J0 | 1248.950 | 508.556 | 377.438 | 92.1167 | 88.8944 | 71.5900 | 61.6042 | 112.0 |
| K0N | 1235.790 | 538.262 | 380.398 | 159.960 | 89.6188 | 72.0536 | 61.9261 | 106.0 |
| K0S | 1299.440 | 566.551 | 396.310 | 167.030 | 93.5956 | 74.5988 | 63.6936 | 108.9 |

6.3.13 Type V 260 – Standard bevel gearboxes

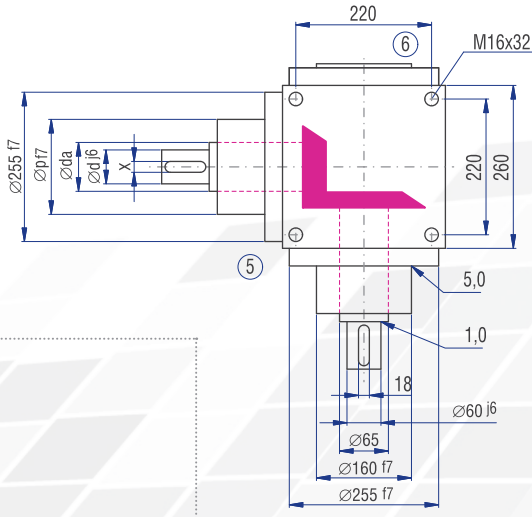
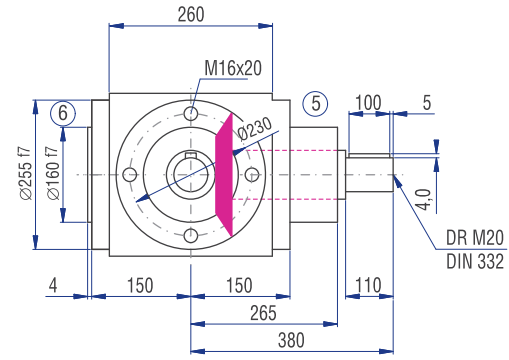
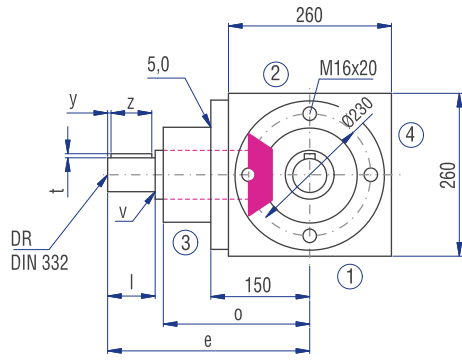
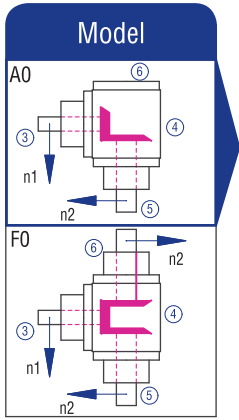

| | Gear ratio | | | | | | |
|---------|------------|-------|-----|-----|-----|-----|-----|
| | 1:1 | 1.5:1 | 2:1 | 3:1 | 4:1 | 5:1 | 6:1 |
| d [mm] | 60 | 60 | 60 | 45 | 45 | 45 | 45 |
| da [mm] | 65 | 65 | 65 | 65 | 65 | 65 | 65 |
| l [mm] | 110 | 110 | 110 | 90 | 90 | 90 | 90 |
| v [mm] | 1 | 1 | 1 | 1.5 | 1.5 | 1.5 | 1.5 |
| x [mm] | 18 | 18 | 18 | 14 | 14 | 14 | 14 |
| y [mm] | 5 | 5 | 5 | 5 | 5 | 5 | 5 |
| z [mm] | 100 | 100 | 100 | 80 | 80 | 80 | 80 |
| t [mm] | 4 | 4 | 4 | 3.5 | 3.5 | 3.5 | 3.5 |
| e [mm] | 380 | 380 | 380 | 360 | 360 | 360 | 360 |
| o [mm] | 265 | 265 | 265 | 265 | 265 | 265 | 265 |
| p [mm] | 160 | 160 | 160 | 160 | 160 | 160 | 160 |
| DR M | 20 | 20 | 20 | 16 | 16 | 16 | 16 |

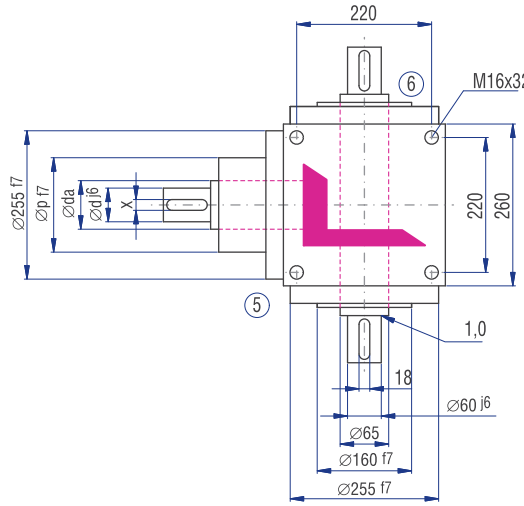
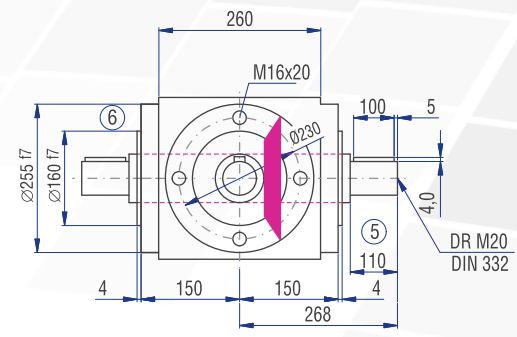
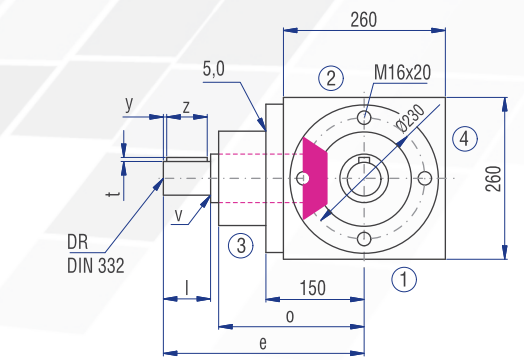
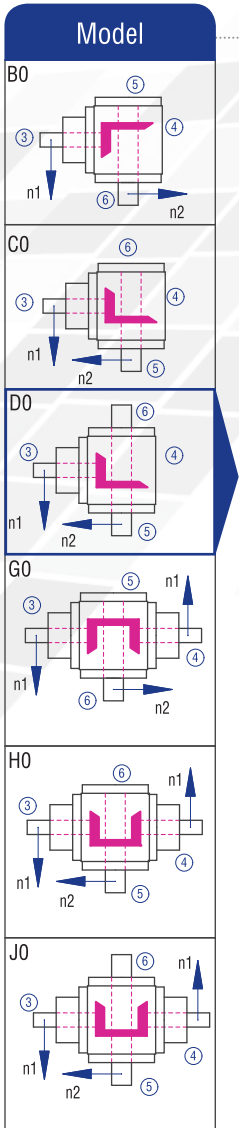

Implementation W

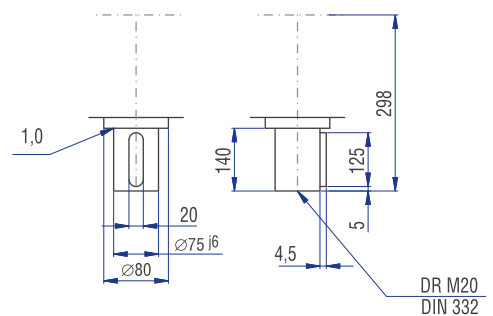

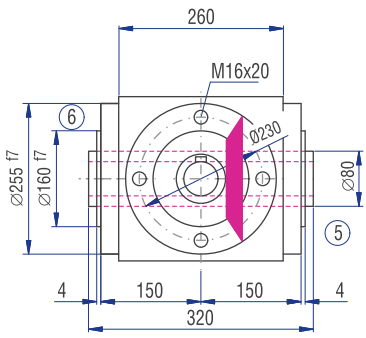
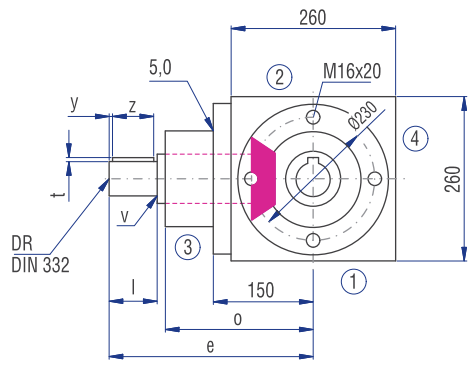

Implementation

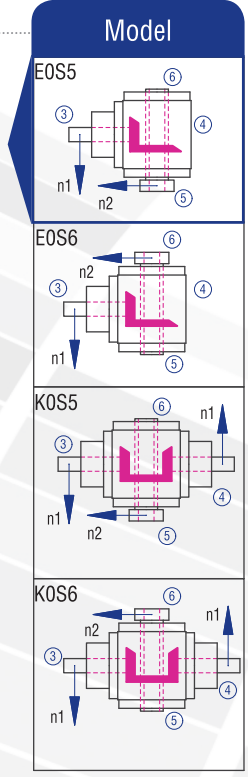
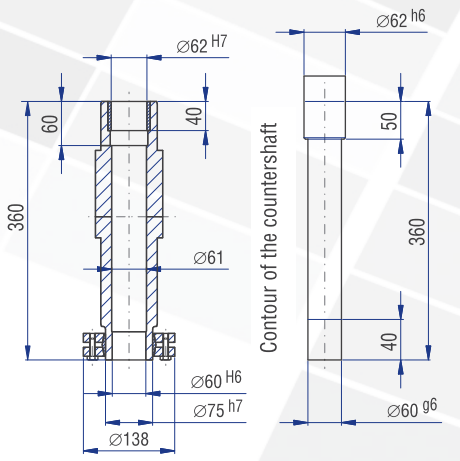
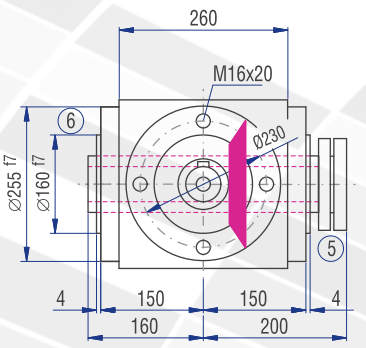
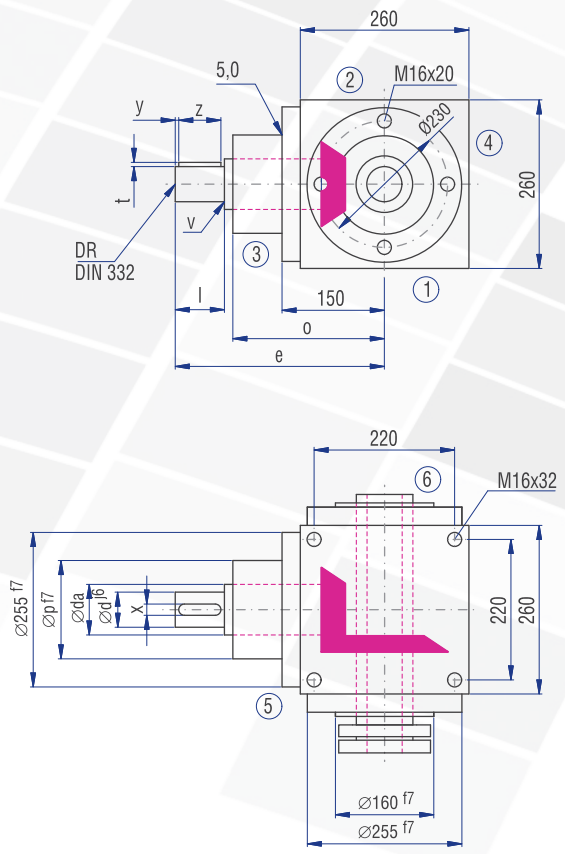
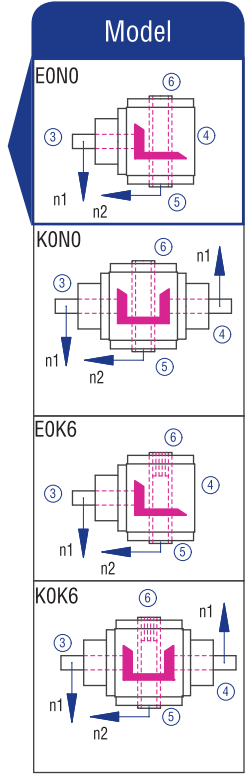
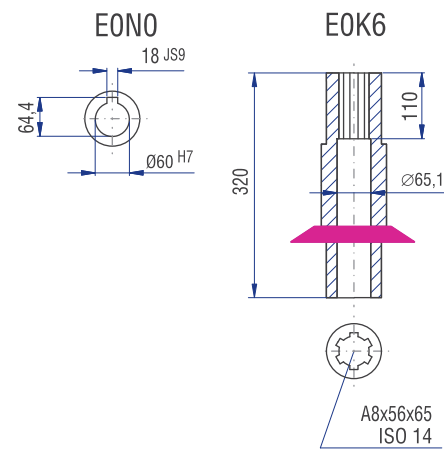
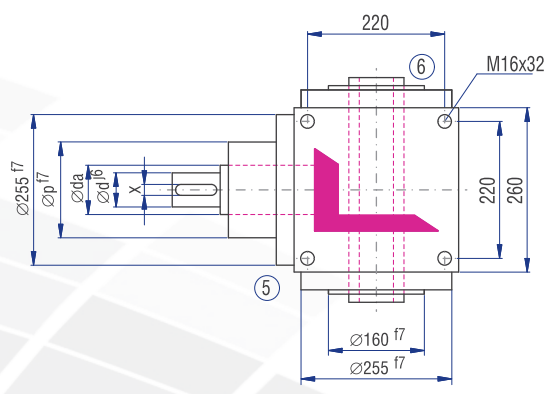

6.3.14 Standard bevel gearboxes – Type V 350

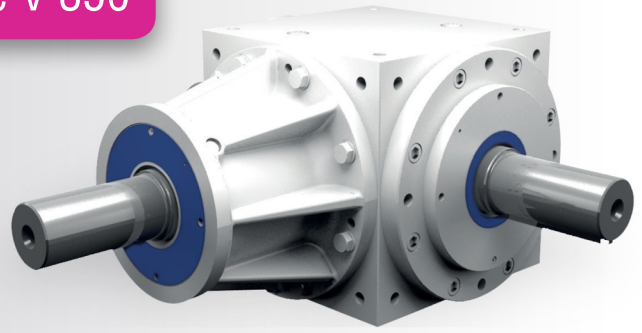

Characteristics

| Characteristic | Standard | Option |
|---------------------------------|--|--------------------|
| Toothing | Spiral toothed bevel gear set | See chapter 6.2.1 |
| Gear ratio | 1:1 to 6:1 | |
| Housing / Flanges | Grey cast iron; steel | |
| Threaded mounting hole | On all housing surfaces without flange and on all flanges. | See chapter 6.2.3 |
| Shaft | Material 1 C45, shaft ends greased Fit with ISO 6 tolerance with parallel keyway: according to DIN 6885 Sheet 1 | See chapter 4.6.2 |
| Hollow shaft | Material 1 C45, shafts greased Fit with ISO 7 tolerance with parallel keyway: according to DIN 6885 Sheet 1 | See chapter 4.6.3 |
| Radial shaft seal ring | NBR, form A | See chapter 4.8 |
| Ambient temperature | -10°C to +90°C. The values of the performance tables are valid for +20°C | See chapter 4.9.3 |
| Circumferential backlash | < 30 arcmin | See chapter 6.2.10 |
| Protection class | IP 54 | See chapter 4.5 |
| Corrosion protection | Prime coat; layer thickness > 40 µm | See chapter 4.4.1 |
| Bearing life L10h | more than 15,000h | See chapter 4.9.1 |
| Oil change intervals | Not required if the oil temperature is kept < 90°C The lifetime of the bearings can be increased by the factor 1.5 if the oil is changed after the first 500 service hours and then every 5000 service hours. | See chapter 6.2.8 |
| Lubricant | Synthetic lubricants | See chapter 6.2.8 |

Performance data

| n_1 [rpm] | 1:1 | | 1.5:1 | | 2:1 | | 3:1 | | 4:1 | | 5:1 | | 6:1 | | | | | | | | |
|-----------------|----------------|------------------|------------------|----------------|------------------|------------------|----------------|------------------|------------------|----------------|------------------|------------------|----------------|------------------|------------------|-----|-------|-------|-----|-------|-------|
| | n_2 [rpm] | P_{1N} [kW] | T_{2N} [Nm] | n_2 [rpm] | P_{1N} [kW] | T_{2N} [Nm] | n_2 [rpm] | P_{1N} [kW] | T_{2N} [Nm] | n_2 [rpm] | P_{1N} [kW] | T_{2N} [Nm] | n_2 [rpm] | P_{1N} [kW] | T_{2N} [Nm] | | | | | | |
| 2400 | | | | | | | 800 | 160.48 | 1,820 | 600 | 113.75 | 1,720 | 480 | 78.83 | 1,490 | 400 | 56.88 | 1,290 | | | |
| 1500 | 1500 | 267.84 | 1,620 | 1000 | 206.19 | 1,870 | 750 | 200.06 | 2,420 | 500 | 122.35 | 2,220 | 375 | 78.95 | 1,910 | 300 | 56.54 | 1,710 | 250 | 41.61 | 1,510 |
| 1000 | 1000 | 210.53 | 1,910 | 667 | 188.55 | 2,560 | 500 | 155.41 | 2,820 | 333 | 96.26 | 2,620 | 250 | 58.14 | 2,110 | 200 | 42.33 | 1,920 | 167 | 31.41 | 1,710 |
| 750 | 750 | 195.92 | 2,370 | 500 | 141.42 | 2,560 | 375 | 129.37 | 3,130 | 250 | 81.29 | 2,950 | 188 | 47.95 | 2,320 | 150 | 35.88 | 2,170 | 125 | 24.25 | 1,760 |
| 500 | 500 | 155.41 | 2,820 | 333 | 112.63 | 3,070 | 250 | 94.52 | 3,430 | 167 | 59.34 | 3,230 | 125 | 34.72 | 2,520 | 100 | 26.67 | 2,420 | 83 | 16.72 | 1,820 |
| 250 | 250 | 94.52 | 3,440 | 167 | 67.11 | 3,650 | 125 | 54.15 | 3,930 | 83 | 34.26 | 3,730 | 63 | 19.43 | 2,820 | 50 | 16.09 | 2,920 | 42 | 9.28 | 2,020 |
| 50 | 50 | 24.47 | 4,440 | 33 | 16.34 | 4,500 | 25 | 12.79 | 4,640 | 17 | 7.79 | 4,240 | 13 | 4.17 | 3,030 | 10 | 3.56 | 3,230 | 8 | 1.95 | 2,120 |
| P_{1Nt} [kW] | 90.0 | | 90.0 | | 90.0 | | 90.0 | | 90.0 | | 90.0 | | 90.0 | | | | | | | | |
| T_{2max} [Nm] | 5400 | | 5200 | | 5000 | | 4500 | | 3500 | | 3500 | | 2300 | | | | | | | | |

Permissible radial force F_{r1} and axial force F_{a1} on shaft N_1

| n_1 [rpm] | 3000 | | 1000 | | 500 | | 250 | | 100 | | 50 | |
|-------------|-----------|-----------|-----------|-----------|-----------|-----------|-----------|-----------|-----------|-----------|-----------|-----------|
| T_2 [Nm] | F_r [N] | F_a [N] | F_r [N] | F_a [N] | F_r [N] | F_a [N] | F_r [N] | F_a [N] | F_r [N] | F_a [N] | F_r [N] | F_a [N] |
| < 2400 | 14500 | 7250 | 15000 | 7500 | 17500 | 8750 | 22500 | 11250 | 27500 | 13750 | 33000 | 16500 |
| > 2400 | 12000 | 6000 | 12500 | 6250 | 14500 | 7250 | 18700 | 9350 | 23000 | 11500 | 27500 | 13750 |

Permissible radial force F_{r2} and axial force F_{a2} on shaft N_2

| n_2 [rpm] | 3000 | | 1000 | | 500 | | 250 | | 100 | | 50 | |
|-------------|-----------|-----------|-----------|-----------|-----------|-----------|-----------|-----------|-----------|-----------|-----------|-----------|
| T_2 [Nm] | F_r [N] | F_a [N] | F_r [N] | F_a [N] | F_r [N] | F_a [N] | F_r [N] | F_a [N] | F_r [N] | F_a [N] | F_r [N] | F_a [N] |
| < 2400 | 17500 | 8750 | 18100 | 9050 | 21100 | 10550 | 26150 | 13075 | 34200 | 17100 | 40200 | 20100 |
| > 2400 | 14500 | 7250 | 15080 | 7540 | 17580 | 8790 | 21790 | 10895 | 28500 | 14250 | 33500 | 16750 |

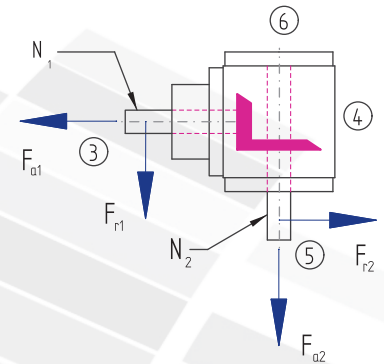

Inertia moments/mass

Inertia moment J_1 related to the fast-rotating shaft (N_1)

| Model | Inertia moment [kgcm ²] | | | | | | | Mass [kg] |
|-------|-------------------------------------|---------|---------|---------|---------|---------|---------|-----------|
| | 1:1 | 1.5:1 | 2:1 | 3:1 | 4:1 | 5:1 | 6:1 | |
| A0 | 3388.00 | 1707.00 | 1021.00 | 585.000 | 473.000 | 296.000 | 261.000 | 269.0 |
| B0 | 3634.00 | 1793.00 | 1063.00 | 605.000 | 485.000 | 304.000 | 266.000 | 280.0 |
| C0 | 3634.00 | 1793.00 | 1063.00 | 605.000 | 485.000 | 304.000 | 266.000 | 280.0 |
| D0 | 3699.00 | 1822.00 | 1079.00 | 612.000 | 489.000 | 306.000 | 268.000 | 287.0 |
| E0N | 3459.00 | 1716.00 | 1019.00 | 586.000 | 474.000 | 297.000 | 262.000 | 259.0 |
| E0S | 3694.00 | 1820.00 | 1078.00 | 612.000 | 489.000 | 306.000 | 268.000 | 264.0 |
| F0 | 5082.00 | 2593.00 | 1573.00 | 805.000 | 606.000 | 386.000 | 317.000 | 340.0 |
| G0 | 5328.00 | 2613.00 | 1533.00 | 969.000 | 825.000 | 511.000 | 471.000 | 372.0 |
| H0 | 5328.00 | 2613.00 | 1533.00 | 969.000 | 825.000 | 511.000 | 471.000 | 372.0 |
| J0 | 5393.00 | 2642.00 | 1549.00 | 976.000 | 829.000 | 513.000 | 473.000 | 379.0 |
| K0N | 5153.00 | 2536.00 | 1489.00 | 950.000 | 814.000 | 504.000 | 467.000 | 351.0 |
| K0S | 5388.00 | 2640.00 | 1548.00 | 976.000 | 829.000 | 513.000 | 473.000 | 356.0 |

6.3.14 Standard bevel gearboxes – Type V 350

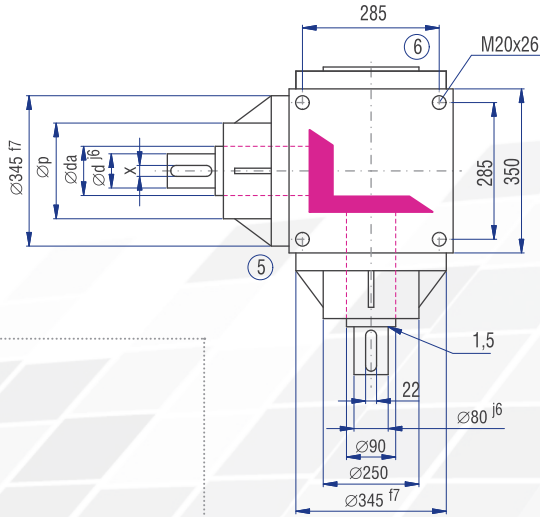
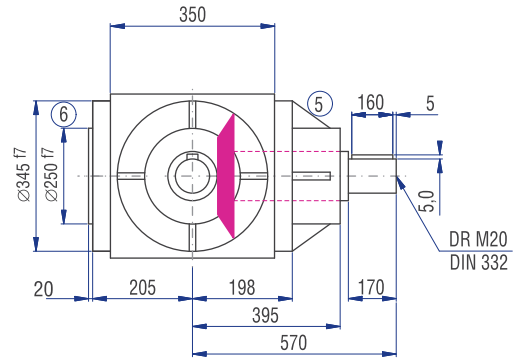
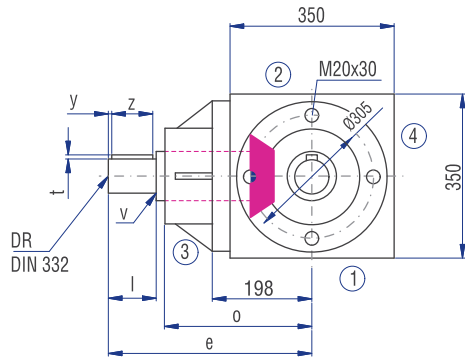
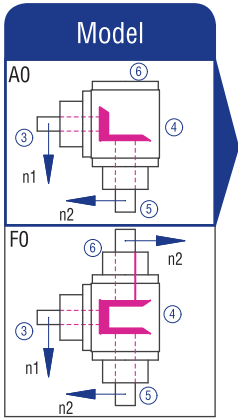

| | Gear ratio | | | | | | |
|---------|------------|-------|-----|-----|-----|-----|-----|
| | 1:1 | 1.5:1 | 2:1 | 3:1 | 4:1 | 5:1 | 6:1 |
| d [mm] | 80 | 80 | 80 | 65 | 65 | 55 | 55 |
| da [mm] | 90 | 90 | 90 | 90 | 90 | 72 | 72 |
| l [mm] | 170 | 170 | 170 | 140 | 140 | 110 | 110 |
| v [mm] | 1.5 | 1.5 | 1.5 | 1.5 | 1.5 | 1.5 | 1.5 |
| x [mm] | 22 | 22 | 22 | 18 | 18 | 16 | 16 |
| y [mm] | 5 | 5 | 5 | 7.5 | 7.5 | 10 | 10 |
| z [mm] | 160 | 160 | 160 | 125 | 125 | 90 | 90 |
| t [mm] | 5 | 5 | 5 | 4 | 4 | 4 | 4 |
| e [mm] | 570 | 570 | 570 | 540 | 540 | 510 | 510 |
| o [mm] | 395 | 395 | 395 | 395 | 395 | 395 | 395 |
| p [mm] | 250 | 250 | 250 | 250 | 250 | 250 | 250 |
| DR M | 20 | 20 | 20 | 20 | 20 | 20 | 20 |

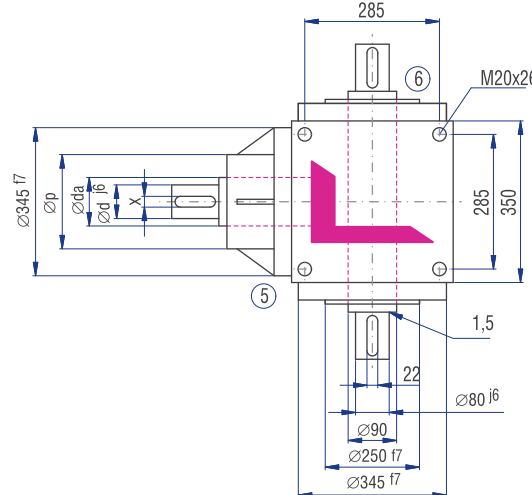
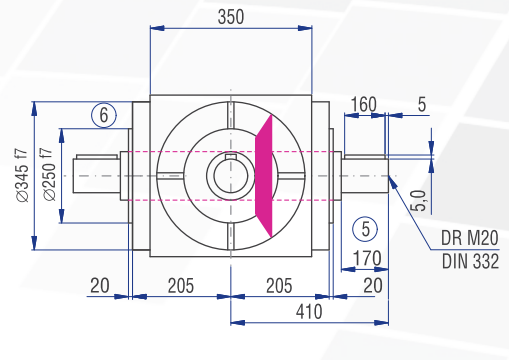
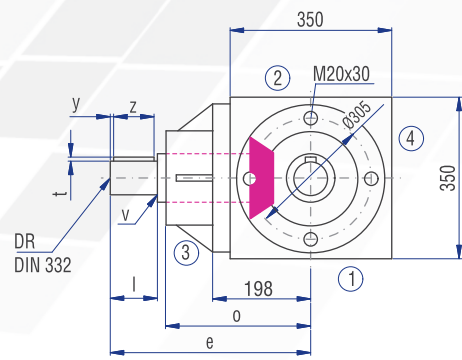
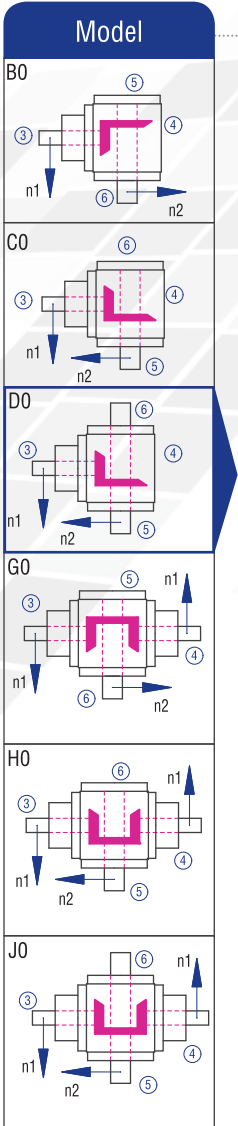

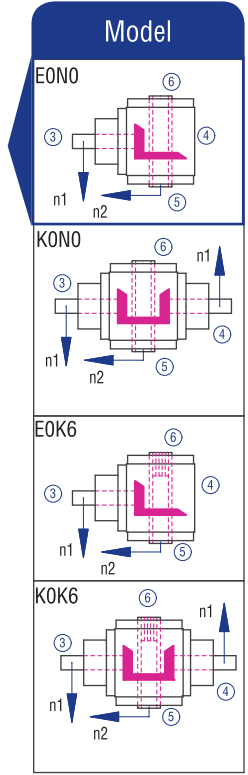
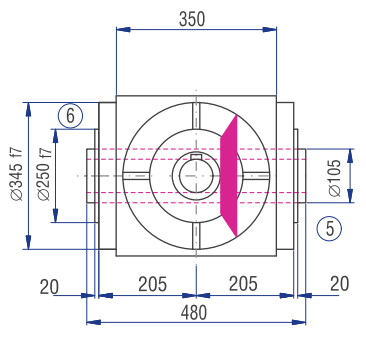
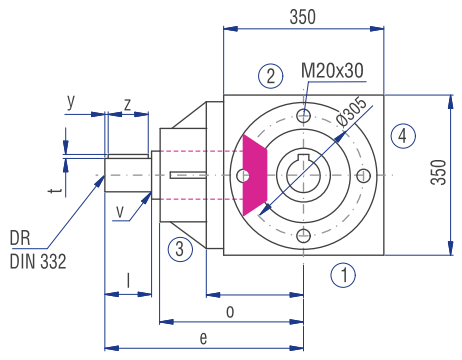

Implementation

